



seedling shelter



When it's freezing out and you want to get a jump on spring, nothing beats this cold frame.

Not being much of a gardener myself, when my wife decided to get into gardening I had a learning curve to overcome. I wasn't aware that the growing season starts late in the winter months rather than the spring. Around here (Ohio) it's too cold to get the vegetables started without the aid of a cold frame. What's a cold frame? Simply a mini-greenhouse. The interiors should be painted with light colors to reflect as much light and heat as possible. The top is mostly glass (or Plexiglas) to generate solar heat, and the lid needs to be adjusted at least twice daily to prevent mold from growing because of the condensation that forms in this cozy little plant-friendly environment.

As designed, this cold frame will keep three flats of seedlings safe from the elements. I didn't feel like adjusting a lid all the time, and Lee Valley Tools came to the rescue with a heat-activated window opener that opens and closes as the ambient temperature changes, eliminating the daily lid adjustment. This project takes only a couple of weekends to complete, so you'll have your seedlings growing in no time.

Begin construction by cutting out the parts according to the cutting list. The box is made up of an upper and lower box that nest together in rabbets. Cut the box parts to size and mill the $\frac{1}{2}$ " x $\frac{7}{16}$ " rabbets in what will be the top edge of the lower box and the bottom edge of the top box. This rabbet allows the two boxes to nest together and make a taller unit when your seedlings mature and need the room.

After cutting the box parts to length, cut 45° angles on the ends and cut two biscuit joints in each corner. Clamp two halves of a joint together to form a square corner, making it easier to use a biscuit joiner. Dry-clamp the top box together and lay out the angle for cutting the pitch of the box to better catch the sun's rays. Use a jigsaw to cut the angle on the sides, then use a table saw with the blade angled

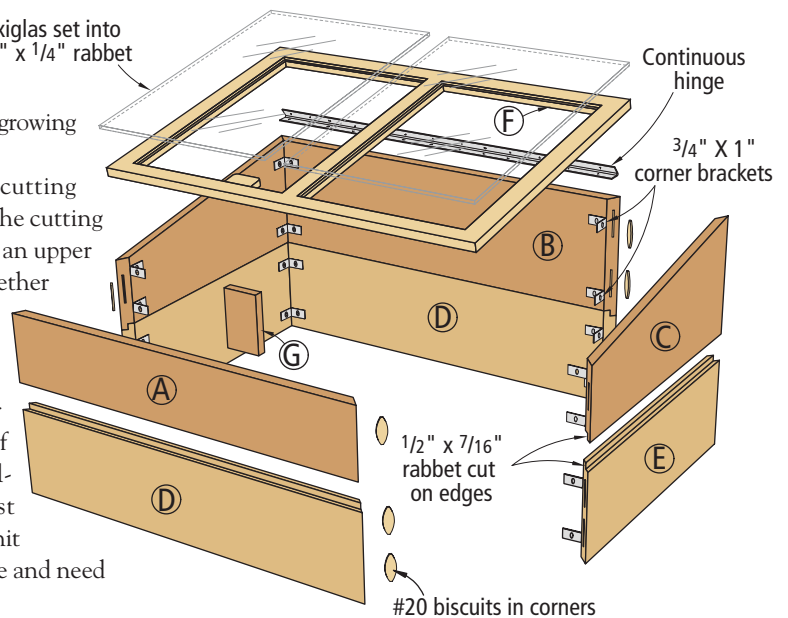

by Jim Stuard

Jim is a former associate editor and now divides his time on the projects he is most proud of: his children, his writing and teaching woodworking.

Photo by Al Parrish.

SEEDLING SHELTER

NO.	LET.	ITEM	DIMENSIONS (INCHES)			MATERIAL
			T	W	L	
1	A	Top box front	3/4	6	32 1/2	CDX Ply
1	B	Top box back	3/4	10	32 1/2	CDX Ply
2	C	Top box sides	3/4	10	22 1/2	CDX Ply
2	D	Bot box frnt and bk.	3/4	8 1/2	32 1/2	CDX Ply
2	E	Bot box sides	3/4	8 1/2	22 1/2	CDX Ply
1	F	Lid	3/4	24	33 1/2	CDX Ply
1	G	Hinge mounting tab	3/4	3	5	CDX Ply



When your seedlings start to kick into high gear, you can add the second box to the seedling shelter to give them more room to grow.

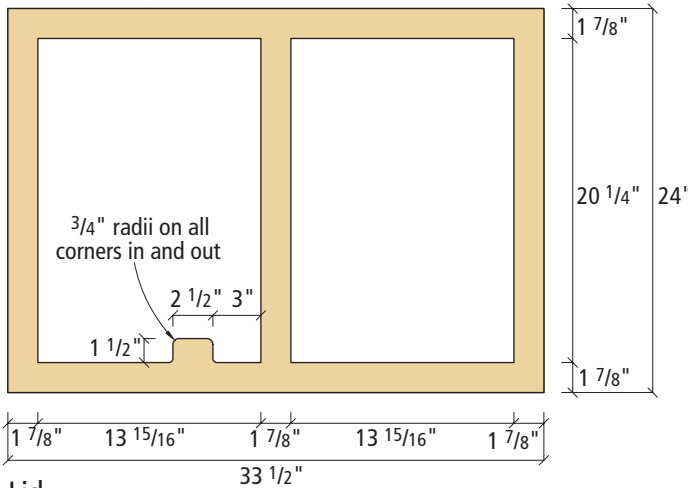

Lid

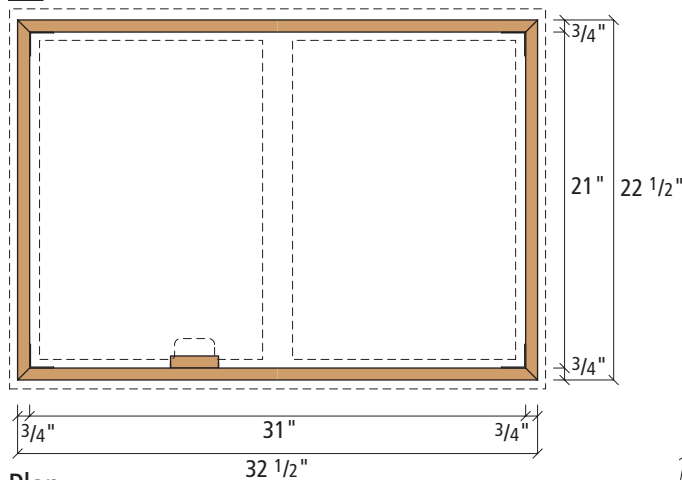

Plan

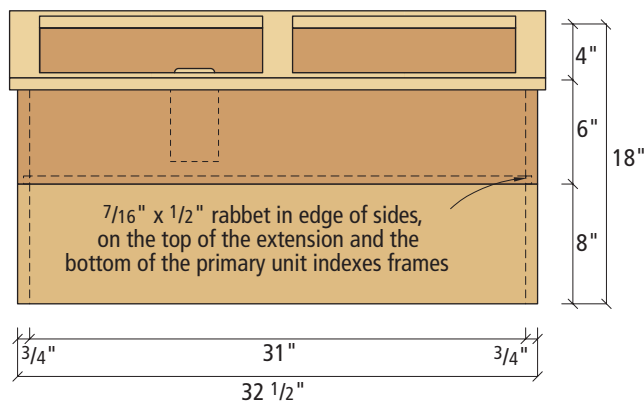

Elevation

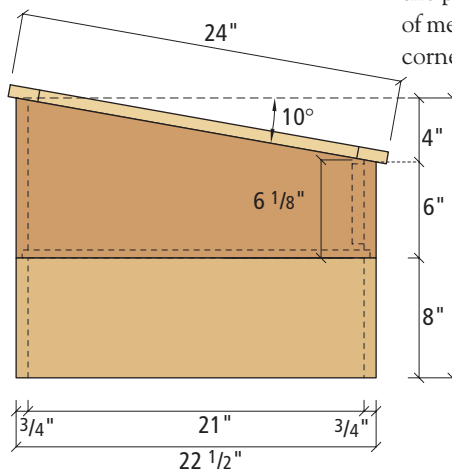

Profile

to bevel-cut the top edges on the front and back pieces. You'll be cutting away one of your biscuit joints, but you'll be adding corner braces later to reinforce the frames. Use polyurethane glue in each joint to make the boxes water-resistant. When the glue is dry, plane all the edges flush and then check the fit between the top and bottom boxes.

Now make and attach the lid. Cut it out of one piece of plywood, then make the cutouts according to the diagram. Take a router with a rabbeting bit and cut a 1/4" x 1/4"-wide rabbet on the top edge of the cutouts to accommodate the thickness of the Plexiglas. The adhesive used to hold the Plexiglas in place later will leave it a little proud of the lid surface and will help the lid

shed water. The mounting tab for the window opener (Lee Valley Tools, 800-871-8158, item #AM401, \$47.00) is located between two seedling flats when they're in place. You'll have to plane the top of the tab so it's flush with the rest of the rabbet. Attach the lid with a piece of continuous hinge. Attach the window opener so it doesn't go beneath the bottom edge of the top box when it's on the ground. This takes a little finagling but it can be done. The openings for the Plexiglas pieces are the same size. Cut two "panes" to size and set them aside for later.

Go ahead and paint the entire cold frame with a durable outdoor paint. Use white or at least a light color for good reflectivity. Apply two coats to every surface. When the paint is dry, install a couple of metal corner brackets to each corner for extra support. Attach the lid; glue in the Plexiglas with epoxy and seal the rabbets in the lid with white caulk. Attach the window opener and apply weatherstripping to the joint between the lid and the frame.

Now get to the potting shed for some serious seedling duty. **PW**