

Norm Abram's

ADIRONDACK CHAIR

Steve Shanesy builds an improved
Adirondack chair with
Norm Abram in The New Yankee
Workshop. Build the chair and
learn how Abram works.

I've become keenly aware throughout the years that patience allows time for opportunities to come along that might never have been possible. Such is the case with this Adirondack chair built in The New Yankee Workshop with Norm Abram.

Although projects similar to this one are common fare for most woodworking magazines, *Popular Woodworking* hasn't printed one for more than 10 years. The project has been discussed, of course, but for one reason or another, it never happened. Then one day the phone rings and a representative of "The New Yankee Workshop" asks if we'd like to work with Abram to build the most popular project ever shown on the show.

Abram would build a chair and give it away as a promotion for the show and I'd build a duplicate as a project for the *Popular Woodworking* readers. Perfect!

OK, some of you are certainly wondering, "What is it like working with Abram right there in The New Yankee Workshop?" So let's get that part out of way. The most surprising thing was just how "Norm-al" it was, if you'll pardon the pun.

When you pare away all the myths and misinformation, Abram is just a very likeable, easy-going, hard-working, down-to-earth

woodworker in a reasonably well-equipped, but not extravagantly so, woodshop. He was very much at home there. And it's not a TV studio set with woodworking equipment, but a real woodshop. How fancy? I've seen far more extravagant shops belonging to home woodworkers than this one.

Working with Abram was fun, to be sure. But I spent years working in commercial shops building

hundreds of projects while working with others. And while Abram is a celebrity, his pleasant personality and easygoing manner made me feel right at home, too.

An Improved Adirondack Design

Now back to the project at hand: After getting acquainted at The New Yankee Workshop, Abram and I first inspected the original Adirondack he built, one based largely on a design his father had used years ago. It had weathered well and withstood the elements for more than a decade in continuous outdoor duty. He explained it was made from cypress, an excellent choice for outdoor projects, and he had laid in a supply for our new chairs.

We next reviewed the chair plans, one of those famous "measured drawings" Abram offers viewers at the conclusion of each

by Steve Shanesy with Norm Abram

Comments or questions? Contact Steve at 513-531-2690 ext. 1238
or steve.shanesy@fwpubs.com.

FOR CASH ONLY.



Photos by Al Parrish

show. This copy had some notes about minor modifications Abram intended as improvements. The last thing we did before cutting wood was review several templates he made for the original chair and saved throughout the years. We used these patterns for the curved parts. Drawings for these are included as part of the project plans presented here.

If you begin the project by preparing the patterns and stock to the rough sizes the building will move along pretty quickly. We completed our chairs in less than a day while working at a steady, but moderately easy, pace.

Starting at the Bottom

Essentially, this chair is built from the ground up so the first pieces required are the two side members that slope back from the front, vertical legs. Use the pattern to trace their shape on the stock, then cut them out using the band saw.

Abram suggested we nail the two sides together at the ends in the waste material and stack cut them both to save some time. Then we drum-sanded the sawn edges to smooth the surface.

Next use a gauge block and a miter saw or table saw so you can repeat the same length cut exactly for the lower rear crosspiece, the front crosspiece and the seat slats. Use the pattern that provides the curved shape of the lower rear crosspiece. (Abram's frugal, Yankee blood became evident when he pointed out that by using slightly wider stock than necessary for this part, the waste piece makes the perfect matched curve needed for the rear seat slat.) After band sawing, sand the edges smooth and be sure to set the waste piece aside for later use.

A Little Assembly Work

The first assembly chore is joining the two sides with the front



Cut both chair side pieces at the same time by nailing them together in a waste section of wood. Band saw to the template line then sand the edges smooth.

and lower rear crosspieces. The crosspieces overlap the sides and care should be taken that the ends are flush to the outside edges of the sides. This will help keep your chair square as you build.

The chair parts are assembled using mostly screws, or in a few instances, carriage bolts, nuts and washers. We used stainless steel fasteners knowing they'd stand up to the rigors of life outdoors. These are more expensive than coated or plated fasteners, but in the end are a far better value. Screw lengths are 1 5/8" except

where noted. We also used outdoor adhesives. Abram used 3M brand Marine Adhesive Sealant 5200. Because my chair would be shipped to the *Popular Woodworking* shop in Ohio, I just screwed my parts together so it could be disassembled and more easily shipped. Later, back home, I re-assembled my chair using Titebond III because I couldn't find the product Abram used. In the Midwest, I guess we just don't have so much need for marine-grade adhesives as they do nearer the coasts.

All screw holes should be

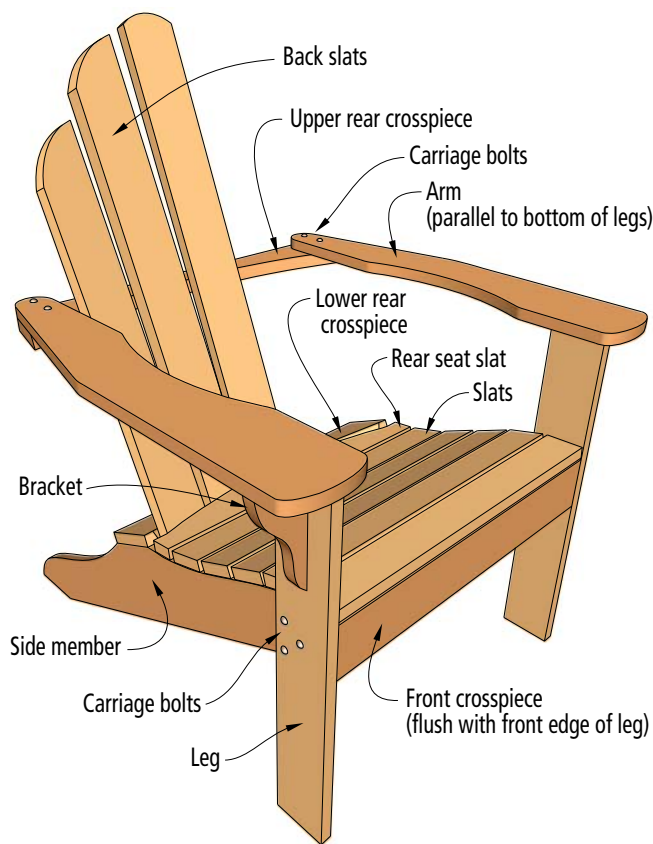

NORM ABRAM'S ADIRONDACK CHAIR

NO.	ITEM	DIMENSIONS (INCHES)			MATERIAL	COMMENTS
		T	W	L		
2	Side members	3/4	5 1/2	34 3/4	Cypress	
1	Lower rear crosspiece	3/4	5 1/2	22	Cypress	Use waste for rear seat slat
1	Front crosspiece	3/4	3 1/2	22	Cypress	
2	Front legs	3/4	3 1/2	23 1/4	Cypress	
2	Arm brackets	3/4	3	6 5/8	Cypress	
2	Arms	3/4	5	27 9/16	Cypress	
1	Upper rear crosspiece	3/4	4 5/16	26 1/4	Cypress	
1	Center back slat	3/4	3 1/2	30 3/4	Cypress	
2	Intermediate back slats	3/4	3 1/2	29 5/8	Cypress	
2	Outer back slats	3/4	3 1/2	25 1/4	Cypress	
5	Seat slats	3/4	2 1/2	22	Cypress	

1 square = 1"

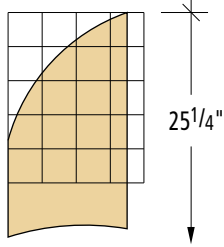

Outer back slat

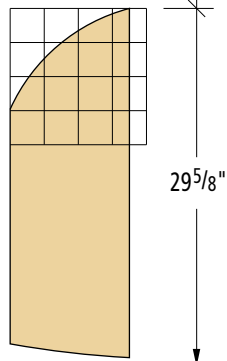

Intermediate back slat

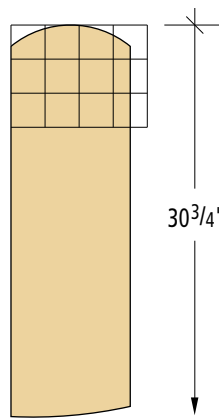

Center back slat

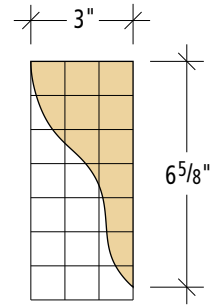

Arm bracket

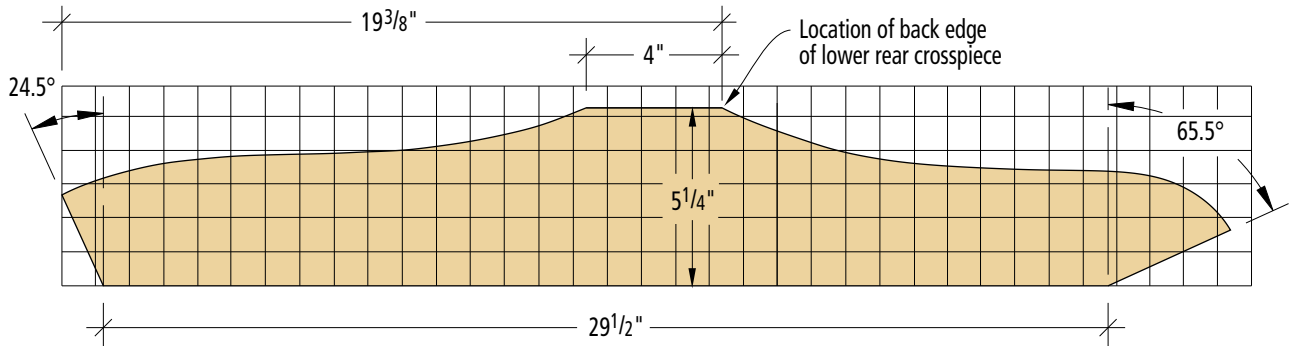

Side member

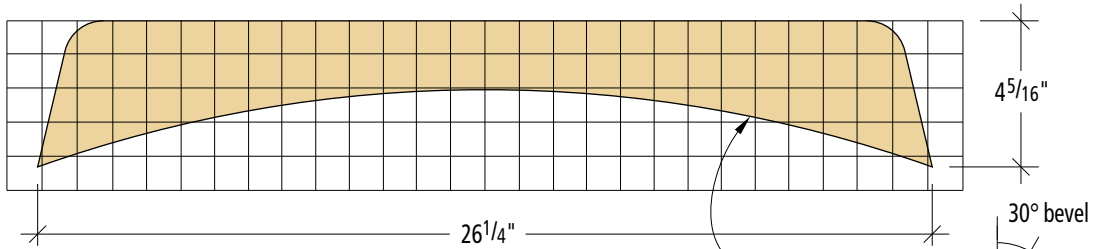

Upper rear crosspiece

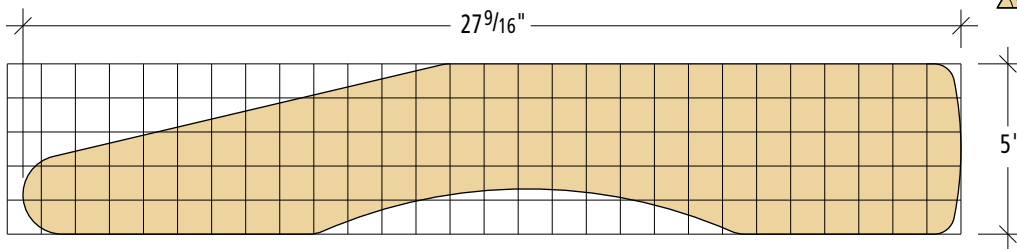

Arm

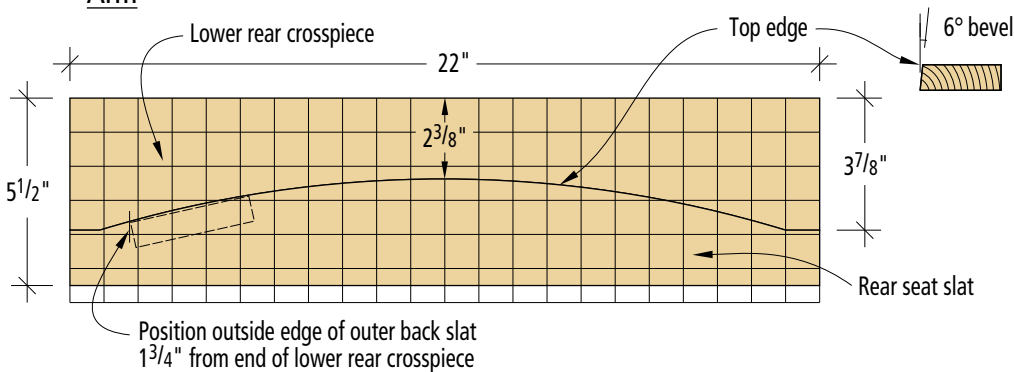

Lower rear crosspiece & rear seat slat

Start the assembly by gluing and screwing the lower rear cross-piece to the chair sides. For lasting results, use a marine grade or waterproof glue, and stainless steel screws.



pre-drilled for a couple reasons; to prevent splitting by drilling a pilot hole and to countersink sufficiently to accept a wood plug later. The plug not only helps the appearance of the chair, but will also add to the chair's durability. We used a bit that drilled the hole and counterbored for the plug in the same operation.

Set up the two sides on the bench and first attach the lower rear cross-piece. When that's in place, turn the work over and fasten the front cross-piece. Use a pair of screws for each connection placing them about $\frac{3}{4}$ " from the edges of the board.

Next the two front legs are attached using three, $\frac{1}{4}$ " by 2"-long carriage bolts. Clamp the legs in position before drilling. The correct position is $11\frac{3}{4}$ " from the

bottom of the leg to the bottom of the front cross-piece.

When locating the bolt holes, arrange them in a triangle as shown in the diagram below. Following the diagram carefully prevented me from placing a hole where a screw for the front cross-piece might be located.

Attach the legs with the carriage bolts, heads to the outside. When tightening the nuts, prevent the head from turning by first seating the bolt head with a hammer blow to engage the square corners in the wood.

Arm and Arm Supports

Next, prepare and attach are the arms and arm brackets. Each requires use of a pattern and should be cut on the band saw. Sand the edges as before. Additionally, the top edges of the arms should be eased using a $\frac{3}{8}$ " roundover bit in a router. We routed only one edge, which designates it a top. So doing will create a right and left arm so choose your edges accordingly.

We attached the arm brackets first. The top, or wide part of the



Drill $\frac{1}{4}$ " holes through the side members and front leg to accept stainless steel carriage bolts. Use a clamp to hold the parts in position; the leg should be flush to the side's front edge and $11\frac{3}{4}$ " up from the leg bottom to the bottom edge of the front cross-piece.

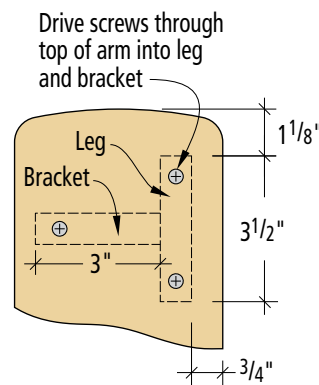

Arm installation over leg & bracket

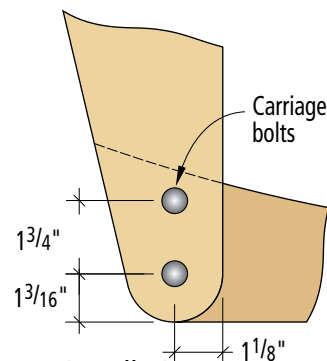

Arm installation over rear cross-piece

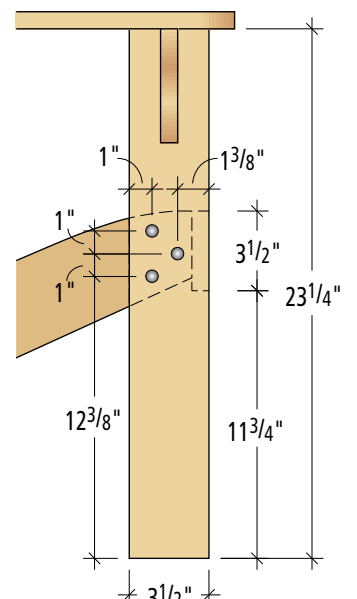

Centers for leg bolt holes

bracket, is positioned flush with the top of the leg and centered on the leg's width. Clamp each one in place then drill and countersink for the upper screw in each bracket. Repeat for the lower screw

but use a shorter, 1¼" screw. With the arm brackets in place, attach the arms to the front legs and bracket. Use the diagram at left to position the arm correctly before fastening. Again, be sure

and use adhesive on each step of assembly as you proceed.

Building the Back

Now prepare the upper rear crosspiece by using the pattern pro-

vided for the inside curve. Note the inside cut is not only curved, but is cut at a 30° angle as well. Tilt the band saw table appropriately then saw the curve. Then return the band saw table to 0°, or square, and cut the ends. Sand the edges.

The upper rear crosspiece is attached below the chair arms. Use clamps to hold the piece in place as you position it correctly, that is, with a 20½" distance between the inside edges at the backs of the arms. That might leave up to a ¼" overhang of the arms at the outside edge. There should be sufficient space to secure the arms and crosspiece with two carriage bolts at each end. Use a spring clamp to hold the parts in place while drilling the ¼" holes for the bolts. When done, install the four bolts.

At this point, your Adirondack chair should begin to take shape. Aside from plugging the screw holes, only installation of the back and seat slats remains.

Back Slats and Seat Slats

The back slats are the first slats to make. Prepare the back slats



Bolt the legs and side members together, bolt head to the outside with a nut and flat washer inside. Seat the square shank below the head with a hammer blow. The shank will prevent the bolt from turning in the hole.



Position and clamp the arm bracket then drill and countersink for two screws. The top edge of the support should be flush with the top of the leg and centered in the width dimension of the leg.



Use three screws to attach the arm to the leg and arm bracket. Carefully position the arm for a ¾" overhang of the leg. Use a spacer to help position it. The arm overhangs the front edge of the leg 1⅛".



Cut the upper rear crosspiece's inside curved edge at a 30° angle. Then return the band saw table to 0°, or square, and cut the round ends.



Hold the upper back crosspiece in place with clamps so that the arms are 20½" apart, then drill each side for two carriage bolts.

by using the patterns for the top edges as shown in the diagram, then band saw the shapes. Both back and seat slats should have their top edges rounded over using a ¼" roundover bit in a router mounted in a router table. Fan out the back pieces in their proper order to make sure you rout the correct edges.

Now install the back slats. To get the right look, proper spacing of the back slats is important. Start with the center slat, placing it dead center in the back. I used four screws for each slat, inserting one in the bottom, then made sure the top was positioned properly, then I secured it with three more. Be careful drilling the screw holes and countersink for the upper crosspiece as these must be done on an angle, drilling straight into the crosspiece, but at an angle to the back slat.

Next, install the outer back slats. Position the bottom of the slat 1" from the inside of the side piece. Secure it, then position the upper portion so that it touches the inside edge of the arm. Fasten it. Once both outside pieces are in place, the remaining two intermediate slats are merely positioned with equal spaces between their adjoining slats.

Now it's time to install the seat slats. Start at the front with the front edge overhanging the front crosspiece by about ¼". Put one screw in each end and use two screws equally spaced attaching it to the front crosspiece.

Continue to add seat slats allowing ¼" spacing between them and fasten each slat with one screw at each end. The final seat slat is the one with the curve, which nests into the curve of the back. Leave space between this slat and the back so water can easily run off.

Finishing Touches

Before finishing up the chair, give in to the temptation to try it out! It's a surprisingly comfortable chair, definitely not the seat to offer a difficult mother-in-law.

Before a final sanding, I grabbed some fall-off cypress and cut about 60 plugs for filling the holes left from countersinking the screws. I used a narrow chisel to pop the plugs loose from the board. I glued the plugs in the holes, leaving them proud. A flexible, fine-tooth saw easily removed the excess plug material.

When all the plugs were glued in and trimmed, I gave my chair a good sanding (#150 grit). The

relatively soft cypress sands easily. While sanding, I made sure any sharp edges were eased.

I decided to leave the cypress unfinished and allow the elements to eventually turn the light brown natural color to a silver gray. I figure by the time that happens, the color will complement what I expect my hair color to be in another 10 years. **PW**

Adirondack Trio

Get Norm Abram's measured drawings and/or a DVD of the complete building process for this Adirondack chair, as well as a matching Adirondack love seat and foot rest, from "The New Yankee Workshop" at <http://bit.ly/Nkf0k3>



Start installing the back slats with the center slat first, then the outer slats. The last two intermediate slats are then easily positioned with equal spacing between their neighbors.