



Japanese Woodworking Tools and Techniques



Shoji Cabinet

BY RYAN SHERVILL



Inspired by a Japanese screen, this cabinet uses traditional and modern joinery.

Designed to divide a room, the shoji screen is both a practical and artistic piece of furniture that's often found in Japanese homes. It was a shoji screen that served as the inspiration for this bookcase. Designed to be very open, this piece is as at home in the center of the room as it is against a wall.

For the construction of this bookcase I combined the traditional with the modern – not only in the design, but also in the construction methods. A spin on Asian design, this bookcase uses modern joinery techniques and materials to their fullest extent. Traditional mortise-and-tenon joints work in tandem with modern materials, fasteners and glues to create a piece of furniture that will not only last for generations, but also comes together easily. This project also makes use of biscuits, dowels and glued-in-place plywood panels, along with more traditional methods, to prove that sometimes a modern approach can be beautiful, strong and functional.



Light and airy. The combination of maple and cherry imparts a lightness to this cabinet, while the opened area near the top and bottom, along with the ventilated shelves, make it airy.

A Modern Approach

The bookcase sits on four gently curved maple legs. To make the legs, select and dress your material to a final thickness of 1 1/4" then clean up the edges. Crosscut the stock to a final length of 61" then rip each piece in half to produce the four legs.

Mark out the curve on one of the rear legs. I marked this curve with a strip of flexible stock with the top and bottom measuring 2 1/2" wide and 1 1/4" at the center.

Rough cut the first leg with a band saw or jigsaw, and complete the curve by sanding up to the lines with a spindle sander. Use this leg to mark the curve on the remaining three leg blanks, but don't cut them out yet.

The front legs each get two 3/8" x 2 1/8" x 1 1/4"- deep mortises. It's easier to mark and cut these mortises while the stock is square. Locate the mortises and make sure the locations mirror each other before you begin.

With the mortises complete, rough-cut the remaining legs at the band saw. Adhere the finished leg to the blanks with double-sided tape to serve as a template, then remove the waste with a couple light passes with a bearing-guided flush-trim bit in the router table – it's a quick operation and results in identical curves.

Due to the curve in the leg, there's a possibility of tear-out as you begin to transition into the exit part of the curve. An upcut-spiral flush-trim bit is a big help here. But if you are limited to a traditional bit, you can minimize tear-out by ensuring your bit is razor sharp and by taking multiple light passes. Or you can stop at the midway point in the leg, then climb-cut the remaining portion.

Spectacular Panel Strength

With the legs done, it's time to construct the front rails and the five panels that make up the sides, back and doors of the case. The panels are all constructed of 3/4" cherry with glued-in-place maple-veneered plywood. Because the incredible strength of glued-in-place panel construction comes from the ply itself, the joinery between the stiles and rails doesn't need to be exceptionally robust nor complex. I chose to use two 3/8" dowels



Shape a gentle curve. Use a spindle sander to shape one leg exactly to your layout line.



Identical curves. Use the shaped leg, along with a router and pattern bit, to create the remaining legs.



A furrow for your panel. A powerfully quick method to form grooves for the plywood panels is a sharp 1/4" router bit and a nice router table setup.

per joint. A dowelled joint is both strong and easy to make with a quality jig.

Begin by cutting the rails for the front of the cabinet and mark a line 1 1/4" from each end. That's the shoulder of the tenons. Using either the table saw with a dado stack or another trusted method, create a 3/8" x 1 1/4" tenon on each end. Test-fit the tenons into the mortises in the legs, then make any adjustments with a shoulder plane or #150-grit sandpaper wrapped around a flat block.

Once the tenon fit is correct, go ahead and cut the 1"-deep curves in each piece. Begin and end the curve 1 3/4" from each end. (You will need that 1 3/4" straight section to accept the knife hinges later on.)

The rear panel is simply a plywood panel glued into grooves in the stiles and rails. Begin by cutting the rear-panel parts (all but the plywood) to the final dimensions. Mark the 1"-deep curve on the top and bottom rails, then cut the curve at the band saw. With a 1/4" bit in the router table, cut 1/4"-wide x 3/8"-deep grooves centered in the stiles and remaining rails. The grooves in the stiles are stopped grooves. Begin the cut 6 1/16" from the top, then end 6 3/4" from the bottom. Mark your start-stop locations on

your stock and make corresponding marks on your fence to show where to start and end your grooves. With the grooves cut, locate and create the dowel holes for joinery.

Dry-fit the frame, determine the plywood panels' sizes then rip the plywood to final dimension. Fit the plywood into the frame. For the strongest assembly, your plywood should fit perfectly into the grooves with no play. Check for square and label each part with a pencil to make re-assembly easier.

Next, mark the location for your dowels then drill the holes. To assemble the rear panel, apply glue the full length of all of the grooves and to the ends of your rails. Insert your dowels with more glue and clamp the assembly together until the glue is dry.

The side panels are constructed in exactly the same manner as the back panel. The only variation is in the length of the rails (cut these to 9 1/2" in length) and the fact that the top rails – those not accepting the plywood panel – are left without the curve found in the back assembly.

Decorated Doors

The doors share a similar construction to the other panels, but there are some differ-

ences. Unlike the other three panels, there are no top or bottom rails, and the top ends of the stiles will be trimmed to final length during assembly.

Cut your stiles to an initial length of 55¹/₄" and the four rails to 12³/₄". Then mark and cut the 1/4" grooves in all of the pieces. The stopped grooves in the stiles are 46³/₈" long, starting at 3¹⁵/₁₆" from the stile bottoms. Cut the plywood panels to size, then test-assemble the doors. Check to make sure everything comes together nicely then mark and drill the holes for the dowels. Apply glue in the grooves and the holes, assemble the doors, add clamps and allow the glue to dry.

In order to add to the organic feel of the design, I incorporated a raised sea grass motif into the panels. In the spirit of keeping things easy, I chose to do this by using an appliqué technique – or as I like to call them, “onlays.”

The blades of grass are 3/16" x 3/16" strips of scrap cherry that I planed to size then brought to shape using a spokeshave, scrap-

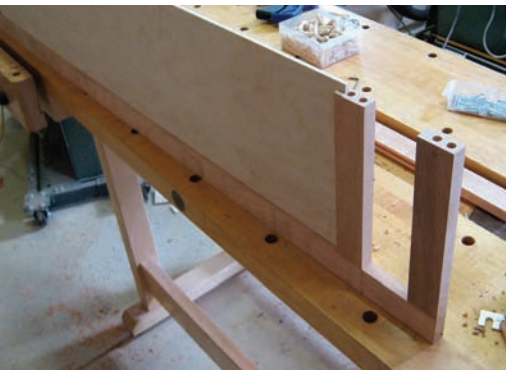

In the process. Here you can see a side panel being assembled. Glue at the joints is common, but a full bead around the panel is only used with plywood.



Artistic flair. Shapely pieces of scrap become appliques that add life to your cabinet.



Scads of adjustment. A dowelling jig makes easy work of the many holes that need to be drilled for the adjustable shelves – or you could use a piece of pegboard. Whichever you select, make sure the holes are equally spaced so your shelves lie flat.

ing plane and a stationary belt sander. (Be sure you leave a flat surface on the bottom of each blade to facilitate attachment.)

The formed and sanded individual blades are then mounted to the surface of the plywood panels with glue and held in place with strips of masking tape or a few 23-gauge pins driven at an angle. Arrange the strips to mirror mine or make your own design. Most of the blades of grass bend easily enough, but for shorter pieces you may want to pre-bend them to shape before applying to the panels. The easiest way to do this is to hold the strips over a pot of boiling water, and bend them to shape while they are in the steam. Hold them in the approximate shape you would like for 30 seconds after removing from the steam, and they will hold with minimal springback.

Ventilated Shelving

With the panels and doors complete, it's time to construct the bottom and shelves for the case. To keep the open feel I chose to avoid solid shelves, and instead went with cherry frames with 3/4"-square maple slats that are arranged inside and doweled in place. For each shelf, mill the pieces for the rails and the ends, then each shelf requires six pieces of maple, each with a 3/8" hole centered in its end to accept a fluted dowel.

Drill matching holes in the end pieces to accept the slats (align the holes for equal spacing) then drill dowel holes, two per end, to join the ends to the rails.

With enough stock cut and drilled to assemble five units (four shelves and the bottom), go ahead and assemble the units – start with the slats and finish with the front and rear pieces. Clamp the units and allow the glue to dry. Once dry, sand the assemblies so the slats are flush with the frames and set them aside.

Preparation Before Assembly

The next step is to drill the holes in the side panels to accept the adjustable shelf pins. I used my dowelling jig equipped with a bushing to drill a series of evenly spaced 1/4" holes. Start the holes 12" down from the top of the panel.

Alternatively, you can use a strip of pegboard and a 1/4" drill bit to locate the holes. The only requirement is that each row of holes is identical and that the shelves sit level after assembly. (Make sure you choose a hole size that accommodates the pins you select.)

The last thing to do before bringing everything together is to cut the mortises in the front rails for the knife hinges. This step is far easier to do on individual pieces rather than once the carcass is assembled. Double check that your rails are oriented correctly then put your offset hinges temporarily in place.

Trace the outside with a sharp knife then chisel out the recess to accept the hinge. Stop at a depth where the hinge body is just slightly proud of the wood's surface. Once satisfied with the fit, drill for the hinge screws. This operation is far easier at this point than it is after assembly.

Supplies

Lee Valley
800-871-8158 or
leevalley.com

1 pkg. ■ brass paddle supports
#63Z06.04, \$8.30

2 ■ Brusso bullet catches
#01B10.08, \$7.40

2 pr. ■ Brusso double offset knife hinges
#01B14.05, \$22.30

Prices correct at time of publication.

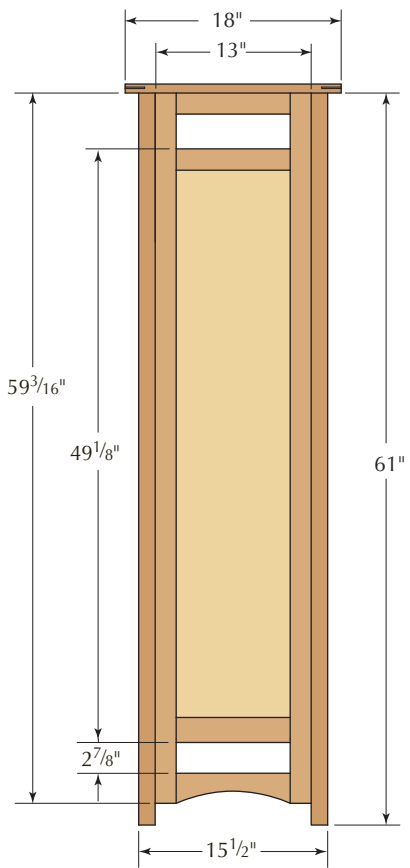

PROFILE

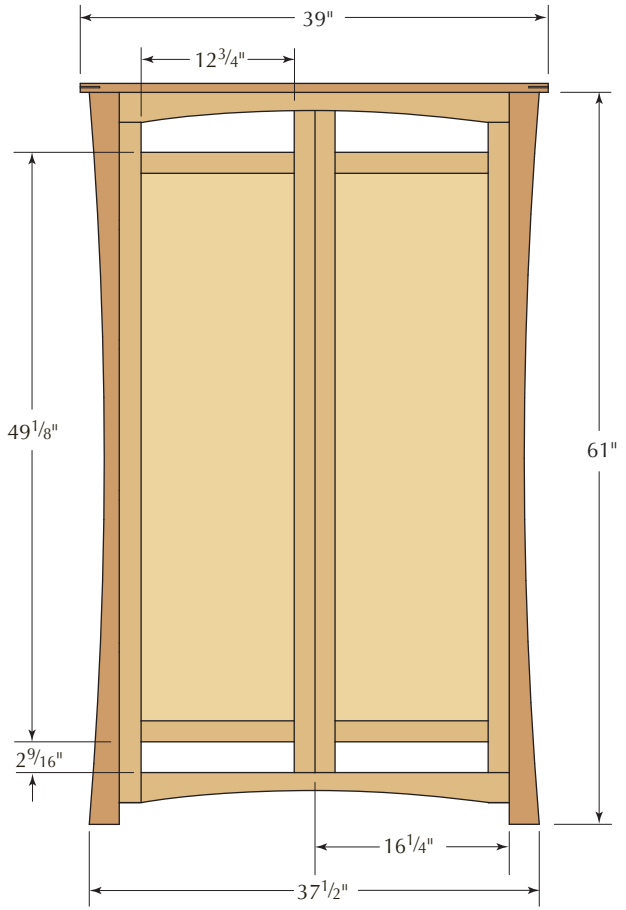

ELEVATION

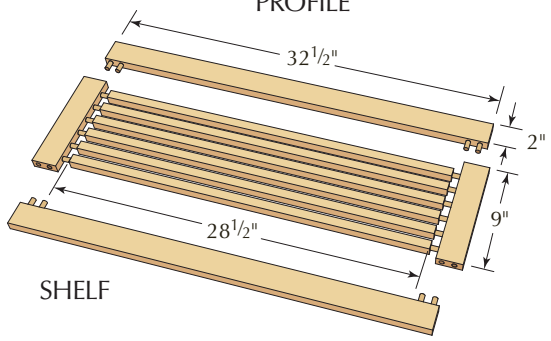

SHELF

Bring it All Together

With five panels, four legs and five shelf units, it's time to bring them all together.

To assemble the case, I use dowels to attach the panels to the legs. Not only do dowels make a strong joint, they aid in the alignment of the pieces. Another benefit is the ability to completely test-fit the carcass without adding glue.

If you prefer to not use dowels, you can use biscuits to help alignment. Or you can carefully clamp the pieces in place with no reinforcement at all. Because these are long-grain-to-long-grain joints, a simple glue joint is sufficiently strong. However, if using the glue-only method, make sure you pay very close attention to the alignment of the panels with the legs. Start by attaching the legs to the front and rear assemblies. Add clamps until the glue is dry.

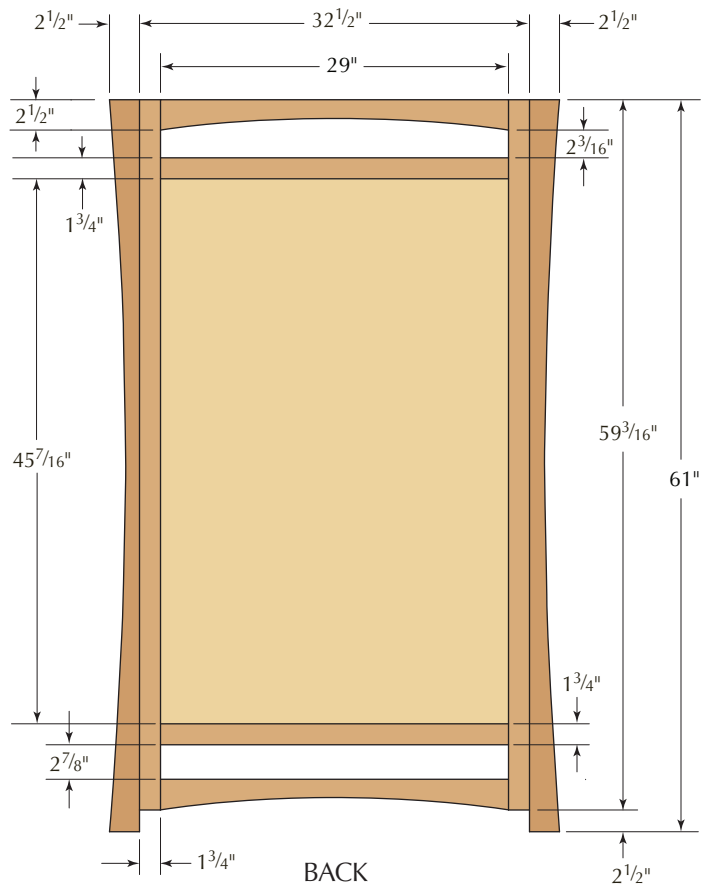

BACK

The next step is to attach the sides to the front and rear assemblies and insert the bottom. If you're using dowels, position them in such a way that at least one dowel passes through the tenon in the front assembly. This way the dowel not only serves to hold the side panels in position, but it also creates a pegged-tenon joint in the front assembly. Test-fit the front and rear assemblies with the side panels.

When bringing all of the pieces together, begin with the case bottom. Apply glue to the edges of the bottom unit then clamp it in place. Next, add glue to the front and back assemblies then fit them to the side panels.

Add clamps and allow the glue to cure. Once the glue has dried, reinforce the bottom. Glue and screw cleats along the intersection of the bottom and panels, ensuring the cleat is glued to both the panels and the bottom.

Top it Off

The top is a $\frac{3}{4}$ "-thick maple panel in a mitered-corner frame of cherry. Cut the maple panel to width and length according to the cut sheet, then create a $\frac{1}{4}$ " centered tongue around the perimeter of the panel using a dado stack, or handplanes if you prefer.

Cut the top-frame pieces to size, miter

the ends at 45° then mill a $\frac{1}{4}$ " x $\frac{3}{8}$ " centered groove on the inside edges of the four pieces.

Wrap the frame around the center panel and ensure you have $\frac{1}{8}$ " of expansion room between the panel and the frame. Next, apply glue to the ends of the miters and a 2"-long or so bead at the center of each end of the panel's tongue – the glue on the end grain will lock the panel in place, but still allow it to expand and contract along its width. Keep the panel centered in the frame and allow the glue to fully cure.

I used splines to reinforce the joints. To cut the slots for the splines, I built a simple



A strong hold. Long-grain-to-long-grain joints have plenty of hold once you get things located. A few well-placed dowels work wonders to align and reinforce the joint.



The case comes together. To fit the side panels between the front and back assemblies is not a challenge. But throw the case bottom into the mix and the balancing act begins.



Keep them centered. The key to a perfect fit is to keep the grooves in the middle of the top's frame pieces, and to work with straight, flat material.



Jig it up. Splines reinforce the mitered corners on the top unit. To cut the slots, it's best to make a jig that slips over your table saw fence as it holds your assembly at a 45° angle.

sled that allows the assembled top to be carried over a 1/8" sawblade. Center the groove and make one pass over each corner. Then make splines to fit the slots. Add glue and slip the splines in place. When the glue is dry, remove the waste material then sand or plane the splines completely flush.

The top is sized to fit the cabinet in such a way that both the center panel and the frame are independently attached to the rest of the cabinet. The center panel is doweled to the side rails, while the cherry frame is glued in place to the front and rear rails.

Drill a centered 3/8"-dowel hole in the top of each side rail and insert dowel centers. Gently position the top so the overhang is set at 2 1/2" at the sides and 1 3/4" at the front. Push the top down to mark the location for the mating dowel holes. Drill the matching holes then add glue and insert the dowels.

Next, run a bead of glue along the top edge of the front and rear rails, and also into the dowel holes in the side rails. Bring the top down into position. Use clamps to hold the top until the glue is dry.

Fit the Doors and More

Fitting the doors requires some trial and error because you need to match the stile lengths to the opening while taking into account the amount of reveal left on your hinges. The easiest way to approach this is to begin by mortising for and installing the lower knife hinge and sliding the door into position. Use a sharp pencil from the inside



No nails needed. The frame of the top is glued to the front and back panels while the top's panel is doweled to the cabinet sides. Get your clamps ready.

of the cabinet to mark where the tops of the stiles overlap the front rail of the cabinet then trim to that line.

Gradually remove material until the door fits properly then install the top hinge. After the hinges are installed and the doors are mounted in the cabinet, check that the doors close. You will likely need to adjust the width of the inner stiles a small amount to provide the clearance needed to prevent the doors from binding against one another. Work to achieve a perfect fit and an even reveal.

With the doors fitting, you need a way to keep them closed. You can make or buy a magnetic catch, or you can install 1/4"-diameter ball-bearing bullet catches, as I did. Locate and drill the holes for the bearing portion, centering them on the bottom rail. Carefully mark and drill the matching hole in the bottom of the inside door stiles, insert the hardware and test the function. Make

any adjustments required then remove the hardware until after finishing.

The Finish Line

To maintain the contrast of the maple against the cherry, I used Target Ultima 6000, a water-based lacquer, as my topcoat to avoid the amber hue from oil-based finishes. Apply four coats of lacquer and scuff sand between coats. Once the finish is fully cured, go over the entire piece with #0000 steel wool to remove any imperfections and knock the finish back to a nice semi-gloss. Follow up with a coat of paste wax, then move the cabinet to its new home. **PW**

Ryan is an award-winning woodworking and outdoor writer who lives in the Georgian Bay Region of Ontario, Canada. When he's not outdoors enjoying the forests and waters surrounding his home, you can likely find him in his rural workshop building custom furniture for clients located throughout North America.

Shoji Cabinet

NO.	ITEM	DIMENSIONS (INCHES)			MATERIAL	COMMENTS
		T	W	L		
4	Legs	1 1/4	2 1/2	61	Maple	
2	Front rails	3/4	2 1/2	35	Cherry	1 1/4" tenon both ends
Back Panel						
2	Back stiles	3/4	1 3/4	59 3/16	Cherry	
1	Top rail	3/4	2 1/2	29	Cherry	Curved edge
1	Bottom rail	3/4	2 1/2	29	Cherry	Curved edge
2	Inner rails	3/4	1 3/4	29	Cherry	
1	Back panel	1/4	29 3/4	46 3/8	Maple plywood	
Side Panels						
4	End stiles	3/4	1 3/4	59 3/16	Cherry	
2	Bottom rails	3/4	2 1/2	9 1/2	Cherry	Curved edge
2	Top rails	3/4	1 3/4	9 1/2	Cherry	
4	Inner rails	3/4	1 3/4	9 1/2	Cherry	
2	Side panels	1/4	10 1/2	46 3/8	Maple plywood	
Doors						
4	Door stiles	3/4	1 3/4	55 1/4	Cherry	Trim to fit opening
4	Rails	3/4	1 3/4	12 1/4	Cherry	
2	Door panels	1/4	13 1/2	46 3/8	Cherry	
Shelves & Bottom						
10	Stiles	3/4	2	32 1/2	Cherry	
10	Ends	3/4	2	9	Cherry	
30	Slats	3/4	3/4	28 1/2	Maple	
Top						
2	Rails	3/4	2 1/2	39	Cherry	45° mitered ends
2	Ends	3/4	2 1/2	18	Cherry	45° mitered ends
1	Panel	3/4	13 5/8	34 5/8	Maple	
Miscellaneous						
2	Long cleats	3/4	3/4	31	Cherry	
2	Short cleats	3/4	3/4	13	Cherry	
70lf	Grass blade	3/16	3/16		Cherry	Rounded, one side flat

Japanese Chisels

BY WILBUR PAN

The hard truth about these ancient tools.

Japanese tools have a reputation of being suitable only for softwoods. This is an unfounded worry, especially in the case of Japanese chisels. As woodworker Kari Hultman (writer of The Village Carpenter blog) attests, “I would like to publicly profess my love of Japanese chisels. All the rest of you chisels can just go home now. I have used the same chisel for chopping and paring maple for days and days and have yet to resharpen it.”

Experience, and knowing what underlies the construction of a Japanese chisel, will empower you to use these chisels in any woodworking task.

Real-deal Steel

Japanese chisels can take an extremely sharp edge that lasts a long time, due mainly to the treatment and type of steel used for the cutting edge. This tool steel typically has a higher carbon content and relatively few alloying elements compared to Western tool steels. That leads to a higher carbide content in the finished Japanese chisel than in Western chisels.

Today, the most common steels used are “white steel” and “blue steel.” The names come from the color of the paper used to package these steels, which are manufactured by Hitachi. The main difference between the two is that blue steel has alloying agents added that give it added abrasion resistance and a more durable edge. But white steel is easier to sharpen, and also can have a durable edge. This is somewhat like the difference between O1 and A2 steels.

The steel in Japanese chisels is hardened to a higher degree than most

Western chisels. Japanese chisels with a Rockwell hardness of 64 or higher on the “C” scale are not uncommon, whereas Western chisels typically have a Rockwell hardness of 60-62. The added hardness results in the edge being less likely to deform under impact, such as when chopping.

Japanese chisels also undergo a forge-welding process in their manufacture. The repeated hammering in this process causes the carbides that are in the steel to become very small and evenly distributed, which results in an extremely sharp and long-lasting edge.

But as Milton Friedman said, there’s no such thing as a free lunch. Having a very hard steel that can take a very sharp edge comes at a cost, and that is brittleness. If an entire chisel were made of a very hard steel, it’s very likely that the chisel would snap under use. That is one reason why Western chisels aren’t often hardened past a Rockwell hardness of 60-62, be-

cause O1 and A2 steels can also become brittle if they are treated to be very hard.

To get around the brittleness issue, Japanese chisels have a second layer of metal forge-welded to the hard layer of tool steel. Traditionally, this layer was wrought iron. The wrought iron layer is softer and thicker than the hard steel layer, which does two things for a Japanese chisel. First, the soft layer acts as a shock absorber, which protects the chisel from cracking under impact due to brittleness. Second, sharpening a Japanese chisel becomes very easy because the hard steel layer can be made quite thin, so that only a small amount of the hard steel on the bevel side needs to be abraded while sharpening.

Comparison of Japanese & Western chisels.

Japanese chisels tend to have shorter blades and overall are shorter than their Western counterparts. From left to right: Japanese bench chisel, Western bench chisel, Japanese timber chisel, Japanese mortise chisel, Western mortise chisel, Japanese paring chisel.





Bevel. This is the bevel side of a Japanese chisel. The difference can easily be seen between the hard layer of steel that makes up the cutting edge, and the soft layer atop it that provides strength to the body of the blade.



Back. The back of a Japanese chisel has a hollow, which aids in flattening the back. Because of the hollow, a relatively small area of hard steel needs to be worked, instead of the entire back as on a Western chisel.

“The expectations of life depend upon diligence; the mechanic that would perfect his work must first sharpen his tools.”

—Confucius (551-479 B.C.),
Chinese philosopher

Field Guide to Chisels

The most common type of Japanese chisel is the *oire nomi*, which is equivalent to a bench chisel. It’s a great all-around chisel, and it can be used for chopping and paring tasks. Some people use these chisels for mortising. There are also Japanese chisels that are equivalent to paring (*usu nomi*) and mortise (*mukōmachi nomi*) chisels.

If the construction of these chisels is examined, they all have features much like their Western counterparts. Japanese paring chisels have longer handles and blades that aid in guiding a straight paring cut, they usually have more acute bevel angles and they should never be hit with a hammer or mallet in use. Japanese mortise chisels are thicker and are set up with a steeper bevel angle compared to bench chisels.

If there is any difference in use between Japanese and Western chisels, it’s the relative size of the chisel. Japanese bench and mortise chisels are typically shorter than their Western counterparts. Japanese paring chisels are closer in length to Western paring chisels, but the blade length tends to be shorter. If there is any reason to prefer Western chisels over Japanese chisels, it’s probably this. Even so, there is a Japanese

Because the back of the chisel is made entirely of the hard steel layer, flattening the back would be quite an ordeal. To make this easier, a hollow is ground into the backside of the chisel so that only a small area of the hard layer needs to be flattened.

This begs the question of what happens after multiple sharpenings, when the cutting edge moves into the hollow on the back of the chisel. All that has to be done is to work the backside of the chisel until a flat is reestablished near the cutting edge. The hollow won’t disappear, because the hollow is slightly deeper toward the handle end of the chisel (see illustration on page 32).

Handle Without (Much) Care

The handle of a Japanese chisel is different than on Western chisels. Most Western chisels either have a tang that sticks into the handle, or a socket that receives the bottom end of a handle that is shaped to fit. Japanese chisels have a combination tang-and-socket

construction, where a cone-shaped ferrule slips over the tang and receives the bottom of the handle, while the tang sticks into the handle of the chisel. This combination is nearly bulletproof in its durability. The socket prevents the handle from splitting at the bottom end, while the tang nearly guarantees that the handle won’t work loose over time.

In addition, the end of the handle of most Japanese chisels has a hoop around it so that it can be hit with a hammer. The hoop is initially set slightly below the end of the handle, and the small amount of wood that protrudes past the hoop is soaked in water then hammered down to form a mushroom to keep the hoop in place. This allows a Japanese chisel to be hit hard without worry that the handle will split.

Some say that the hoop makes paring with a Japanese chisel uncomfortable. I’ve found that if the hoop is properly set, the fibers that mushroom over the hoop cover it so that the metal ring should not be digging into your hand.

COMPOSITION OF WESTERN & JAPANESE CHISEL TOOL STEELS

	O1	A2	White Steel #1	White Steel #2	Blue Steel #1	Blue Steel #2
Carbon	0.95	0.95-1.05	1.25-1.35	1.05-1.15	1.25-1.35	1.05-1.15
Manganese	1.2	1	.02-.03	0.2-0.3	0.2-0.3	0.2-0.3
Silicon	0.4	0.3	0.1-0.2	0.1-0.2	0.1-0.2	0.1-0.2
Chromium	0.5	4.75-5.5	-	-	0.3-0.5	0.2-0.5
Tungsten	0.5	-	-	-	1.5-2	1-1.5
Molybdenum	-	0.9-1.4	-	-	-	-
Vanadium	0.2	0.15-0.5	-	-	-	-
Phosphorus	0.03	0.03	0.025	0.025	0.025	0.025
Sulfur	0.03	0.03	0.004	0.004	0.004	0.004

All values in percentages. Japanese tool steels have 10-40 percent more carbon than O1 and A2 tool steels. This leads to increased carbide content in Japanese tool steels, with white steel #1 and blue steel #1 having more carbon than their #2 varieties. Japanese tool steels tend to have fewer alloying agents than Western tool steels. Increased carbide content or added alloying agents makes the steel more wear-resistant.

WHERE DID 'SOFTWOODS ONLY' START?

Japanese tools have a reputation for being suitable only for softwoods. But if the types of woodworking done in Japan are examined, it's clear that Japanese woodworkers must have been able to work with all kinds of species. Tropical rosewoods and ebonyes were imported into Japan for woodworking, as was done throughout Asia. The most common piece of furniture in the Japanese household is the *tansu* (a storage cabinet with drawers), and it's fairly easy to find examples of *tansu* made with species such as elm, chestnut, ash and mulberry. Yew, although a softwood, is pretty hard to work with, and was used in Japanese furniture. In addition, Japanese white and red oak are uniformly used to make Japanese plane bodies and Japanese chisel handles.

—WP

timber chisel (*atsu nomi*) that is nearly identical to a Japanese bench chisel except that it is longer in length, and is closer to the size of a Western bench chisel (see the opening photo).

Kissing Cousins

Aside from the size, Japanese chisels are quite different from their Western counterparts primarily because of their laminated construction and the back-side hollow, but historically, there were striking similarities between the two.

Today, Western chisels are uniformly made of a single piece of tool steel, but that is a relatively recent development. According to historical tool expert Stephen Shepherd, up until the 1870s, Western chisels were laminated and made with a forge-welding process

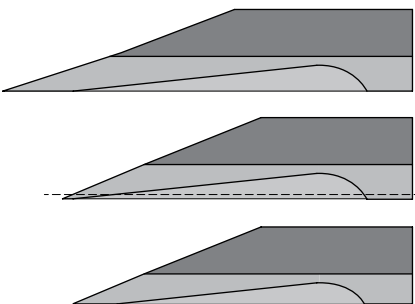

Dealing with hollows. This side view of a Japanese chisel shows the soft layer, hard layer and the hollow (top). As a Japanese chisel gets sharpened, eventually the cutting edge will move into the hollow (middle). The way to deal with this is to work the back of the chisel on your sharpening medium, which will reestablish the flat area in back of the cutting edge (bottom). Because the hollow is deeper at the back of the blade, the hollow will last over the life of the chisel.

that was similar to that used by Japanese toolmakers. Then, Western chisel manufacturing methods switched to using a single piece of tool steel.

Western toolmakers also took advantage of the concept of a hollow on the backside of the chisel as an aid to efficient flattening of the back.

Joel Moskowitz, of Tools for Working Wood, has written that in traditional Western tool manufacturing, some warping of the iron after hardening was inevitable so that one side of the tool became slightly concave; that side was used for the back. The bevel was then ground on the other side. This results in a chisel with a slight hollow to the back that aids in maintaining the back just like it does in a Japanese chisel, although to a lesser degree.

So it appears that although Japanese chisels are different from today's Western chisels, historically they have some key features in common.

Softwoods Only?

It's unclear to me exactly why the idea that Japanese chisels were not suitable for hardwoods developed in the first place. Japanese woodworking has a reputation of using mostly softwood species, but there are plenty of examples of Japanese woodworking using hardwoods and tropical species (see "Where Did 'Softwoods Only' Start?"), so the tools must have been able to deal with those types of wood.

In theory, the harder edge of a Japanese chisel might be more prone to chipping, but in practice I've never found this to be an issue. New Japanese chisels

may be a bit prone to chipping due to overhardening of the edge during the manufacturing process, but this issue disappears over time as the chisel is sharpened past that point. And Western chisels are prone to the same issue.

If Japanese chisels are set up with a bevel angle similar to Western chisels (30° for bench chisels, 35° for mortise chisels, 25° for paring chisels), they can be used in hardwoods with great results. I've been able to chop cocobolo with Japanese chisels and then cleanly pare end grain in pine. Experiences like Kari's while she was building her bench are also common. And if you do run into a piece of wood that causes chipping in a Japanese chisel, simply resharpening the chisel with a slightly higher bevel angle will take care of that, just as it will in a Western chisel.

So why did this softwoods-only stereotype come about? I think part of the answer lies in the fact that furniture did not play as central a role in a Japanese house as compared to a Western house. Also, Japanese architecture favored exposed beams that were usually made from softwood species. Because the most visible aspect of Japanese woodworking was in architecture, the association between Japanese tools and softwoods might have come from there.

But to then say that Japanese tools are only good for softwoods makes as much sense as to say that American woodworking is all about softwoods because there's a lot of pine furniture in the United States, or because our 2x4s aren't made from cherry. **PWM**

Wilbur lives in New Jersey and writes about woodworking on his blog at giantCypress.net.

ONLINE EXTRAS

For links to all online extras, go to:

■ popularwoodworking.com/feb13

BLOG: Visit Wilbur Pan's blog for more on Japanese tools and woodworking.

IN OUR STORE: "Japanese Saws vs. Western Saws," an article by Christopher Schwarz.

TO BUY: "Japanese Hand Tools & Joinery," a DVD by Jay van Arsdale.

Our products are available online at:

■ ShopWoodworking.com



Japanese Saws

VS.

The difference is more than just pushing or pulling.

It might shock you to hear this, but in the last decade or so more than three centuries of a Western tool-making tradition has been undone.

“You cannot push a chain in a straight line. But you can pull a chain in a straight line. Pushing a saw makes no sense. I can saw upside down and over the back of my head with a Japanese saw with no problem.”

— Harrelson Stanley of JapaneseTools.com

The Western handsaw, a tool that cuts on the push stroke and was the pride of the English-speaking world, isn't the tool most woodworkers now reach for when they need a handsaw.

It has been replaced by the Japanese saw, which cuts on the pull stroke and once was mocked by Westerners as “backwards.”

The numbers tell the story best:

- Sixty percent of the saws sold by Lee Valley Tools are Japanese-style, says Rob Lee, president of Lee Valley, one of the world's largest hand-tool catalogs.
- Woodcraft Supply Corp. sells 100 Japanese saws for every Western saw, says Peter Collins, a product manager for the large catalog and retail company.
- And Japan Woodworker, which sold many Western saws

30 years ago, now sells 1,000 Japanese saws for every Western saw, says Fred Damsen, the owner.

What caused this shift to Japanese saws? While some say it's because sawing on the pull stroke is superior to sawing on the push stroke, the issue actually is more complex.

And which saw is best? The prevailing wisdom says Japanese saws are superior and easier for beginners to learn. But if you've ever worked with a sharp, well-tuned Western saw, you know this can't be entirely true.

To answer these questions, we decided to scrutinize the two types of saws to learn their true differences, beyond the information in catalogs. Armed with this knowledge, you can choose a saw that's right for your woodwork-

ing and your budget. Our journey begins in ancient Egypt.

The First Handsaws

Modern woodworkers would almost immediately recognize the first known metal saws, which were excavated in Egypt.

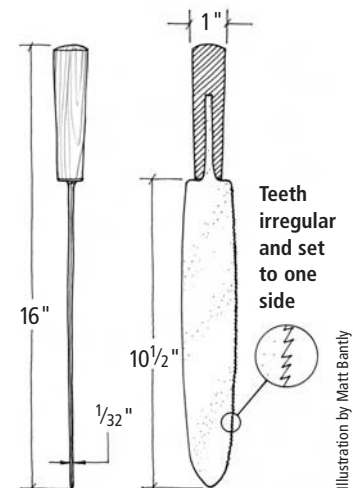

Egyptian handsaw

by Christopher Schwarz

Comments or questions? Contact Chris at 513-531-2690 ext. 1407 or chris.schwarz@fupubs.com



Photos by Al Parrish

Western Saws

They had a long, knife-like blade, a straight grip and cut on the pull stroke, like a Japanese saw. Why the pull stroke?

Early Egyptian saws were made with a thin sheet of copper (as thin as 0.03") and had no rigid spine like the modern backsaw.

“(If they had been used) on the push stroke, the saw would have buckled and bent,” according to Geoffrey Killen, author of numerous books and articles on Egyptian woodworking and the head of faculty at the Design and Technology Department of the Stratton Upper School and

Community College in England.

What is unusual about these saws is that all the teeth were set (meaning they were bent) to one side of the blade. This makes the saw difficult to steer, and the Egyptians had to come up with ingenious ways of wedging the saw kerf open during each cut, according to Killen.

The advent of bronze tools brought some refinements, as did the iron saws developed by the Romans. But the basic form was still a pull saw with a thin blade.

It was the invention of the frame saw (plus teeth set to both



The Western handsaw, shown here being used by Don McConnell with an overhand rip grip, cuts on the push stroke.

“I continue to use Western-style saws mostly because they work for me, and I don’t see enough advantage in pull saws to completely change the way I work and the appliances I use.”

— Don McConnell, contributing editor to *Popular Woodworking*, professional woodworker and longtime student of traditional woodworking

ADVANTAGES OF JAPANESE SAWS:

- Thinner kerf removes less wood, which means less effort.
- The inexpensive saws are of high quality and work very well right out of the box.
- The teeth are generally harder and can go longer between sharpenings. The best Western saws are 52-54 on the Rockwell "C" scale. Japanese saws are 51-58 for the handmade saws, and 61 and higher for the machine-made impulse-hardened saws. While the harder teeth stay sharp longer, they also are more brittle and prone to break.
- There are many manufacturers who sell a wide variety of saws with different teeth configurations (more than 100 kinds, by Harrelson Stanley's count) for every woodworking task and every type of wood.

DISADVANTAGES:

- It's almost impossible for a woodworker to sharpen a Japanese saw. The teeth are too complex on handmade saws and too hard on the impulse-hardened ones. Handmade saws usually go to Japan for sharpening. Impulse-hardened saws become scrapers or go in the garbage.
- The crosscut teeth are more delicate. If you hit a knot or cut quickly into particularly tough wood, you could lose a tooth or two.
- The saws are easier to ruin. Because the blade is thin, you can bend it on the return stroke if you push too hard and the saw isn't aligned properly in the kerf.
- Japanese saws pull sawdust toward you, obscuring your line.
- Japanese saws made for dimensioning lumber (not joinery) have shorter blades than full-size Western handsaws. Depending on the saw, the pull saw might require more strokes to do the same work.
- Japanese saws are designed to be used in traditional Japanese fashion on low benches. When used in Western fashion, some Japanese saws are not always as effective as they should be.

“Here’s a tip for starting a ryoba saw in a rip cut: Start the cut with the crosscut side (to begin your kerf) and then switch to the rip side.”

— Fred Damsen, Japan Woodworker

sides of the blade) that allowed these thin metal blades to be used on either the push stroke or the pull stroke – much like a modern coping saw or bowsaw, according to “The History of Woodworking Tools” (G. Bell & Sons) by W.L. Goodman.

The frame saw might not have been invented by the Romans, but they certainly refined it and produced a wide variety of them.

This is an important fork in the road in saw history that affects us to this day. The Japanese developed pull saws like the Egyptians, but they never seem to have developed frame saws, according to several students of Japanese history (though a Chinese frame saw did come into use in 15th century Japan).

So the Japanese, with their scarce metal resources and their traditions of working low to the ground, stuck with the pull saw and refined it to a high art.

In the West, most of the European continent stuck with the bowsaw. But the Dutch and English took a different path. In the mid-17th century, wider steel blades became possible thanks to water-driven mills, and the modern handsaw that cuts on the push stroke was born.



Instead of benches, Japanese craftsmen use low trestles. Sawing a tenon with a Japanese saw this way is efficient and requires sawing at a less awkward angle than at a high Western bench. However, you need to be in good shape to work this way.

The West Stumbles

The 19th and early 20th centuries were the golden age of Western handsaws. There were hundreds of saw manufacturers, fierce competition, high-quality tools and a very hungry market.

But as the demand for quality hand tools declined, so did the number of manufacturers. And quality slipped dramatically.

“Western manufacturers thought it was OK to ship a saw that was poorly set, dull and had a handle that looked like it was made by a third-grade art student,” says Thomas Lie-Nielsen, owner of Lie-Nielsen Toolworks. “You couldn’t use the saws right out of the box. It’s no wonder the Japanese ate their lunch.”

When Western saws suitable for cabinetmaking disappeared off the shelves, the Japanese saws picked up the slack.

“In Japan, the product lines have not been cheapened,” says Lee of Lee Valley Tools. “Even products that have been mass produced have not been cheapened.”

So while it was tough to find a decent new Western saw at almost any price, the Japanese exported saws to the West that were sharp, straight, perfectly set and inexpensive. A good Japanese backsaw still costs only about \$40. So it’s little wonder that the Japanese saw now is in many North American workshops. It was, in many ways, a simple matter of economics.

Facts About Japanese Saws

Japanese craftsmen would be quite curious about the way Westerners use their saws. For one, we work on a high bench and clamp our work when sawing. The Japanese furniture maker works on a low sawhorse (6" high or so) and does not generally have a vise.

“(Westerners) tend to clamp everything,” says Harrelson Stanley of JapaneseTools.com. “The Japanese don’t clamp unless they have to. They do some wedging. Mostly they saw in toward a solid object,” such as the work, which is secured by their foot, he says.

A second difference is that many Westerners use the crosscut dozuki saw (a saw with a rigid spine) for cutting dovetails, which is primarily a ripping operation.

The Japanese woodworker instead uses a rip-tooth dozuki (which is uncommon in the West) or a rip saw without a back, says Damsen of Japan Woodworker. That’s because the Japanese philosophy on dovetails and tenons

“Don’t choose a tool based on hype. There’s no reason you should have to buy something made 10,000 miles away to cut wood.”

— Pete Taran, Vintage Saws

is, at times, different than the Western approach.

“When they cut dovetails they don’t want the cut too smooth,” he says. “They compress the joint before assembly and let it expand and lock the joint.”

Westerners want a smoother cut and are willing to sacrifice the speed of a rip tooth. Many Japanese dovetail saws for the Western market have some sort of combination tooth, in some cases a tooth that was designed to cut plywood that also works quite well for dovetails, Damsen says.

Types of Japanese Saws

But one thing Japanese and Western craftsmen share is hav-

ing to choose what type of Japanese saw to buy: a machine-made saw or a craftsman-made saw. There are important differences:

- A good-quality machine-made saw costs about \$20-\$50. The price of a craftsman-made saw averages \$150, and the premium tools are about \$250.

- Generally, craftsman-made saws have softer teeth than the machine-made saws, which are typically impulse-hardened. Impulse hardening is a fast, high-voltage process that hardens only the teeth. While the machine-made saws stay sharp longer, they cannot be resharpened.

Craftsman-made saws can be resharpened and even customized to the way you work. But this is meaningless to Western woodworkers, says Frank Tashiro, owner of Tashiro Hardware, which sells the line of ZETA Saws.

“(The sharpener) doesn’t know your work so he does the best he can, so it doesn’t work out,” says Tashiro, who adds that the best value and performance come from a Japanese saw with replaceable impulse-hardened blades.

But replaceable blades rankle woodworkers who don’t believe in disposable tools.

To counter that, Japanese saw manufacturers say that once your impulse-hardened saw becomes too dull for woodworking, it is still plenty sharp for work in the garden as a pruning saw.

“You can make a nice scraper out of the blade, too,” Damsen says of the saws.

- Another difference is that

ADVANTAGES OF WESTERN SAWS:

- The teeth are more durable than those on Japanese saws and are highly unlikely to break, even under the worst conditions. The blades themselves are thicker and less likely to buckle in use.

- They will last you a lifetime. The teeth can be resharpened many times. Saws can even be refilled by the user to a different tooth configuration if their needs change.

- With a little practice, you can sharpen a Western saw with inexpensive and easy-to-obtain tools.

- Western dovetail saws that are properly filed for a rip cut will cut more aggressively than the crosscut-filed dozuki that’s commonly used for dovetails in the United States.

- They push the sawdust away from your cut line.

- High-quality secondhand Western saws are both plentiful and inexpensive in most parts.

DISADVANTAGES:

- High-quality new or restored Western saws are more expensive than their Japanese counterparts. Japanese joinery saws average about \$45; the equivalent quality Western saw costs \$125.

- Inexpensive new Western saws are – in general – dull and poorly set compared to similarly priced Japanese saws. Learning to saw with these less-expensive tools frustrates many beginners, swearing them off Western saws.

- While vintage Western saws are plentiful in most parts of the United States, you must first learn to restore them before putting them to work: straightening the blades, fixing the teeth and sharpening.

- The teeth are softer and require more frequent sharpening, though it is a task you can do yourself after a little education and practice.

- In general, the saws are heavier and have a thicker kerf, so they require more effort to use.



For crosscutting in joinery, the Japanese will use a dozuki (which means “shoulder of a tenon”). There are various ways to grip the saw.



Some students of woodworking history think the push stroke was developed in the West because we work on high benches, unlike Japanese craftsmen who work near the floor on low trestles or beams.

many craftsman-made saws are more delicate because of their thinner blades. Even the most robust craftsman-made saw should not fall into the hands of a beginning woodworker.

“Just because you have a \$200 saw doesn’t mean you will saw better,” says Stanley. “It’s important to practice the technique. Start with impulse-hardened saws. Don’t get a \$250 saw and break it. As your skills improve you can use thinner saws.”

When using Japanese joinery saws, most everyone agrees that you shouldn’t be aggressive or saw at a radical angle. Just a bit of downward pressure on the pull stroke is all it takes, and you shouldn’t apply any downward pressure on the return push.

Facts About Western Saws

No one can deny that Japanese saws cut very well, but so do Western saws that are sharp and properly set. The problem is find-

ing Western saws suitable for woodworking. There are still some manufacturers of full-size Western saws that do a decent job for woodworking, including E. Garlick & Son, Pax, Paragon, Sandvik/Bahco, Lynx and Augusta. Some of them also make joinery saws – backsaws with a rigid spine on the blade. And companies such as Lie-Nielsen and Adria now make premium joinery saws that are the equal of the outstanding saws of the 19th century.

But by far, the biggest sources of quality Western saws are flea markets and auctions. Top-of-the-line Disston, Simonds and E.C. Atkins saws can be purchased for \$5-\$25. These, however, can be rusty, dull and bent. If you have no desire to restore one of these old saws, there is an alternative.

Pete Taran runs the web site VintageSaws.com, which is a sawyer’s paradise. He takes classic handsaws and backsaws and returns them to their former glory by making them sharp, properly set and ready to cut. A vintage highly tuned handsaw or backsaw will cost between \$80 and \$150 at Vintage Saws.

The site also is a treasure trove of good historical information on saws. One of Taran’s primary goals is to teach woodworkers how to sharpen their Western saws, which is easier than you might think.

He sells the files and saw sets you need, plus there is a fantastic tutorial on his web site that explains the process from start to finish. And if you just want to get your feet wet, Taran even offers a saw filing kit to get you started. The kit comes with a user-grade saw with freshly cut teeth, a file, a file handle and complete instructions. When you’re done, you’ll have some more confidence and a saw that cuts very well.

Sharpening a Western saw is probably one of the biggest stum-

bling blocks for woodworkers.

“No one knows how to sharpen Western saws,” says Graham Blackburn, author of “Traditional Woodworking Handtools” (available at blackburnbooks.com) and an instructor at Marc Adams Woodworking School. “I ask the students to bring in their worst plane and their worst saw. Once they sharpen their saws they never go back to Japanese saws.”

But if you don’t want to learn to sharpen, you still can get a flea-market saw professionally tuned.

We recommend Tom Law of Smithsburg, Md. We mailed a dull, unusable Disston backsaw to Law, who charged us \$10 to reshape the teeth, \$5 to set the teeth and \$10 to sharpen the 14-point rip saw. That \$18 saw now cuts dovetails like a dream. (See the “Saw Sources” box for contact information. Law also has a tutorial video, “Hand Saw Sharpening.”)

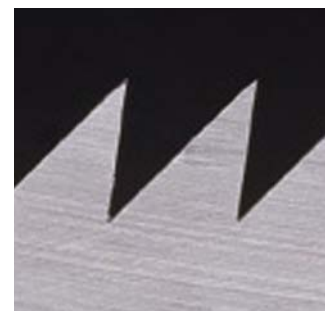

Japanese Rip Teeth • The length of the rip teeth are graduated on Japanese saws. They start small near the handle and get larger.

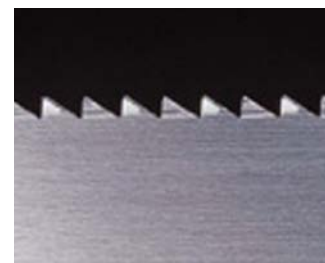

Western Rip Teeth • Rip teeth work like chisels, levering out the grain. Crosscut teeth work like knives, severing the fibers on either side.

“My favorite illustration has been pruning a tree. Imagine standing 30 feet up, hanging onto a trunk about to remove a branch above you. Would you rather be pushing or pulling?”

— Rob Lee, president, Lee Valley Tools

This \$18 Disston #4 backsaw cuts incredibly well now that it has been properly sharpened. The handle on vintage Western saws will fit your hand like a glove. Later handles are uncomfortable to use and look crude by comparison.



Western Saw Tips

Once sharpened, a Western saw is easier to use than you might think. Here are a few tips:

- Though it sounds obvious, use a rip saw for rip cuts, such as dovetailing. Some dovetail saws are filed for crosscut. They work

OK, but not as well as a rip saw.

- Let the saw do the work. Don't use a lot of downward pressure on the kerf – this is surely the No. 1 problem faced by beginners. The saw will wander and you'll never cut straight.

- Don't clench the handle tightly. Hold the saw with just enough pressure to keep it under control. And use only three fingers – your index finger should point down the blade.



Japanese Crosscut Teeth • Note the long slender teeth and three bevels filed on each tooth. The tips are discolored from impulse-hardening.

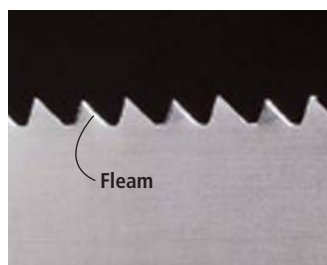

Western Crosscut Teeth • You can see the simpler secondary bevels (called the "fleam") filed on every other tooth.

Worst of Both Worlds?

All this has to make you wonder why someone hasn't built a saw that merges the best qualities of both traditions. Well, a few companies have tried, though nothing has been able to challenge the dominance of the pure Japanese-style saw.

And the reason might be illustrated by the experience of one veteran woodworker.

A few years ago, Blackburn was poking around a flea market and discovered a beautiful old Spear & Jackson backsaw.

The saw had a perfectly shaped handle, much like the one on the outstanding Lie-Nielsen dovetail saw. But the blade of this Spear & Jackson was horribly bent. So Blackburn hung it on his wall.

“I take issue with Japanese saws being easier to use for beginners. I think it's just the opposite. A sharp and tuned Western saw is much easier to learn to use.”

— Thomas Lie-Nielsen, Lie-Nielsen Toolworks

One day a friend noticed the saw and offered to send it to Japan to see if they could straighten it out. Blackburn agreed. The saw came back a few months later straight as an arrow but with one major and shocking change.

They had filed Japanese-style teeth on the blade. Trying to keep an open mind, Blackburn gave it a try. “It cuts well,” he says, “but it feels wrong to me. So it still hangs on the wall.”

Chalk it up to this: When it comes to traditional hand-tool skills, it's hard to defy tradition. Now you just have to decide which tradition is best for you. **PW**

SAW SOURCES

Adria Woodworking Tools
604-710-5748 or adriatools.com
• Premium Western joinery saws

BlackburnBooks.com
• Books and videos on traditional Western woodworking

DisstonianInstitute.com
• Detailed information on Disstons

EuropeanHandTools.com
888-222-8331
• E. Garlick and Lynx saws

Geoffrey Killen's Egyptian Site
geocities.com/gpkillen/
• Information on Egyptian wood-working tools and furniture

Hida Tool
800-443-5512 or hidatool.com
• Range of Japanese saws

Japan Woodworker
800-537-7820 or japanwoodworker.com
• Full range of Japanese saws and some Western saws

JapaneseTools.com
877-692-3684
• Range of Japanese tools, including some hard-to-find types

Lee Valley Tools
800-871-8158 or leevalley.com
• Impulse-hardened Japanese saws
• Wide range of Western saws

Lie-Nielsen Toolworks
800-327-2520 or lie-nielsen.com
• Premium Western joinery saws

Tashiro Hardware
206-328-7641 or tashirowhardware.com
• Impulse-hardened Japanese saws

Tom Law
301-824-5223 or 62 W. Water St.,
Smithsburg, Md. 21783
• Western saw sharpening

VintageSaws.com
• Restored vintage Western hand-saws and sharpening supplies

Woodcraft Supply Corp.
800-225-1153 or woodcraft.com
• Impulse-hardened Japanese saws and some Western saws

Get More Great Woodworking Resources!

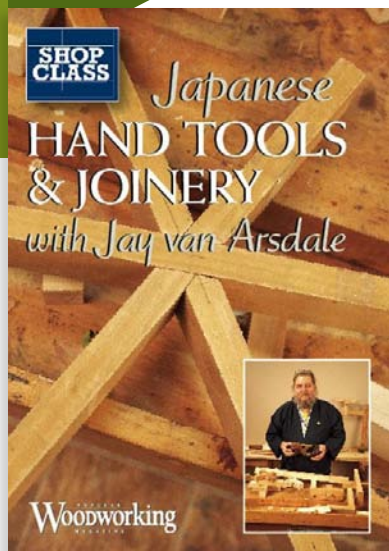

Your free download contains excerpts from the **February 2010**, **February 2013** and **October 2003** issues of *Popular Woodworking Magazine*. You'll find a lot more projects, tips and techniques at ShopWoodworking.com. Visit our online store today, and continue building your knowledge!

Buy the full contents today!