

**RICE PADDLE**

**Cutlist**

No.	Items	Dimensions (inches)		
		T	W	L
1	<b>A</b> Spatula sled	3/8	15	8 1/2
4	<b>B</b> Holding pegs	5/16	5/16	-
2	<b>B</b> Spatulas ( <i>left &amp; right</i> )	3/8	2 3/4	12
1	<b>C</b> Rice paddle	3/8	2 3/4	10
1	<b>D</b> Salad tongs	3/8	2 3/4	12

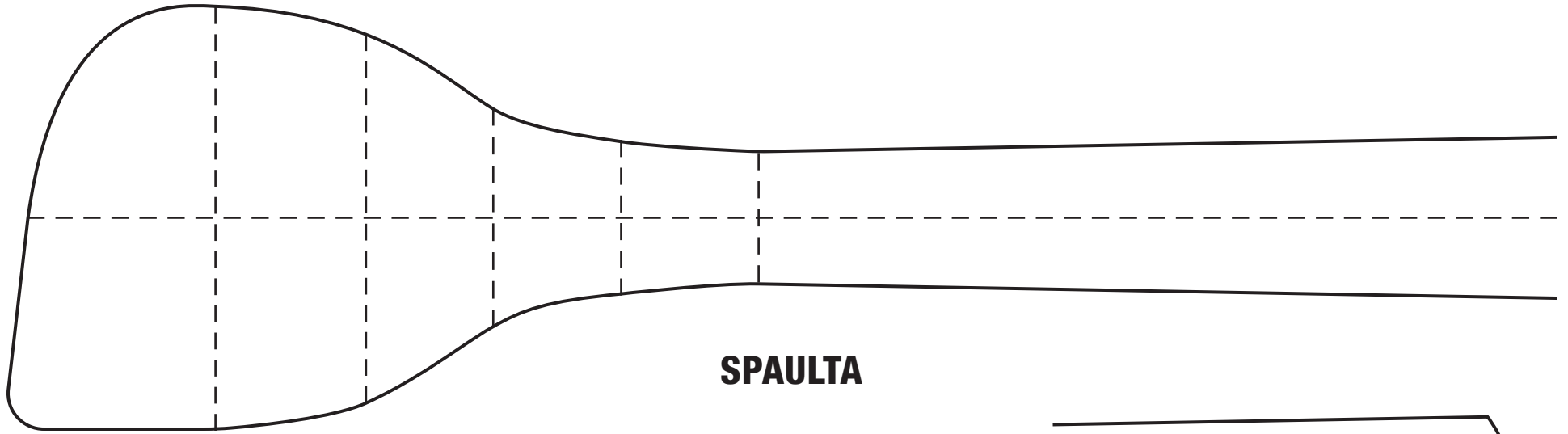



**SPAULTA**

**TO ASSEMBLE TEMPLATE:** Print, cut, and tape the two pieces together. Note, there is 1" overlap to ensure accurate assembly.

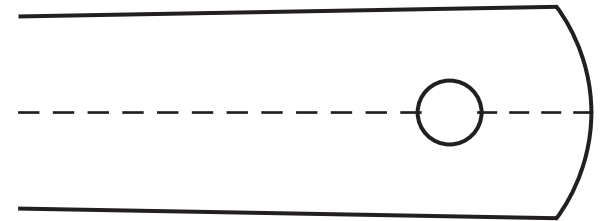

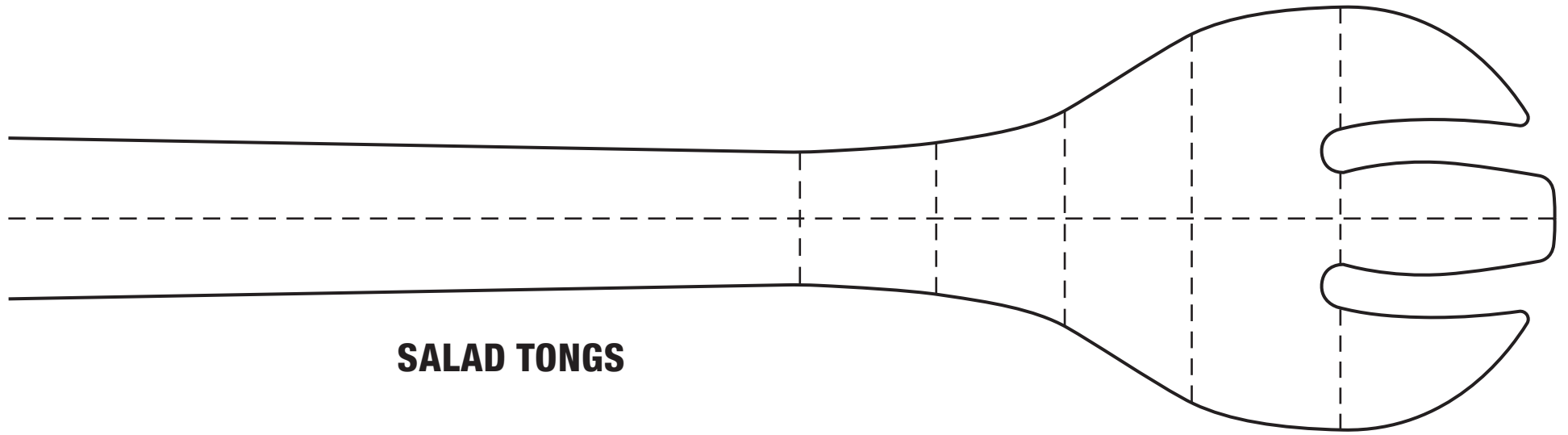

**SALAD TONGS**

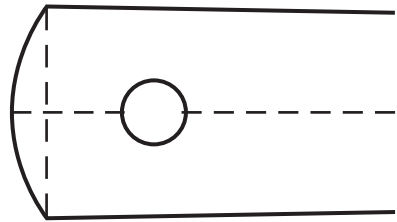

**TO ASSEMBLE TEMPLATE:** Print, cut, and tape the two pieces together. Note, there is 1" overlap to ensure accurate assembly.

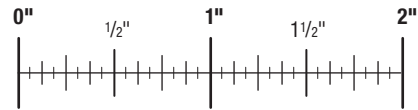

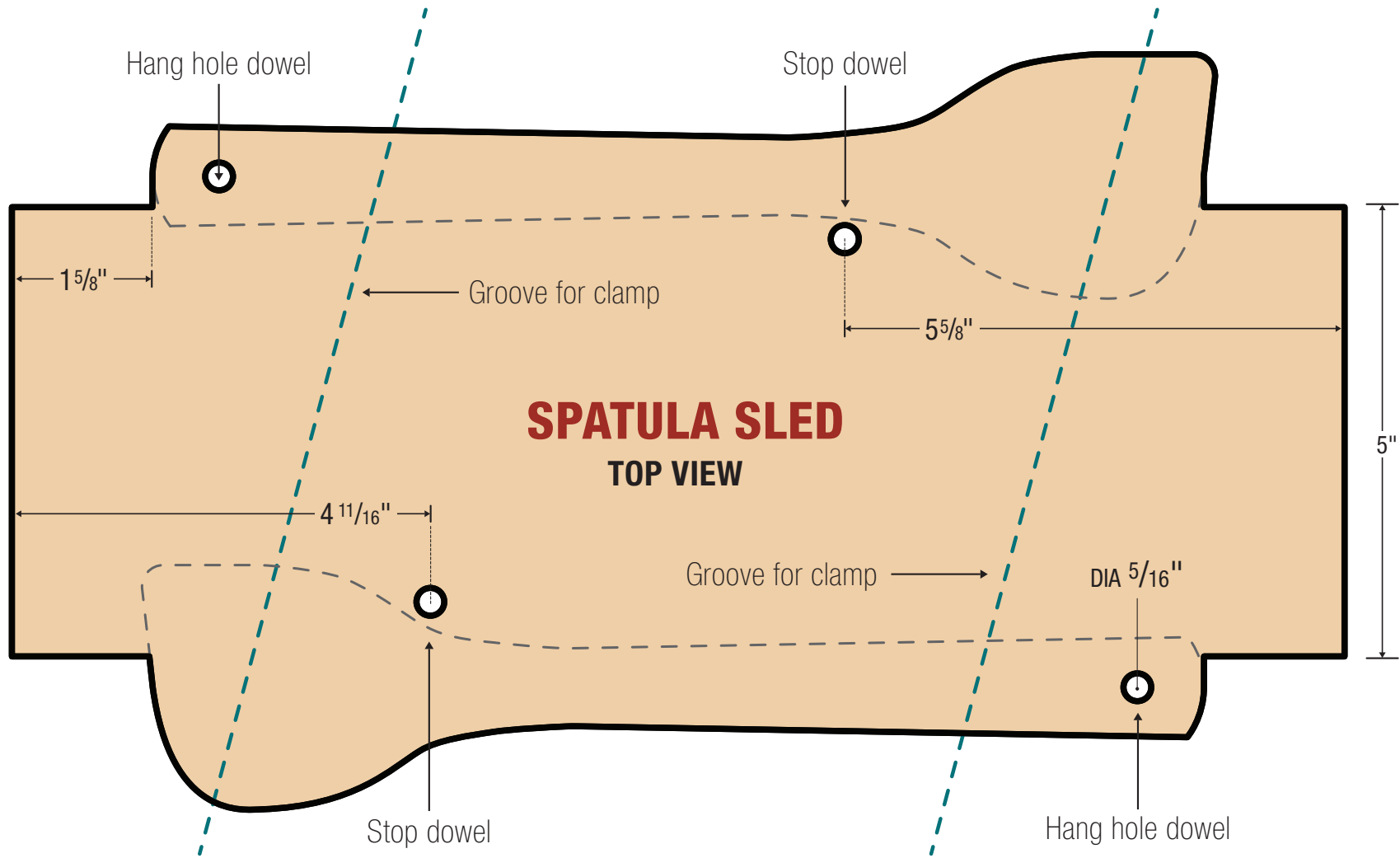

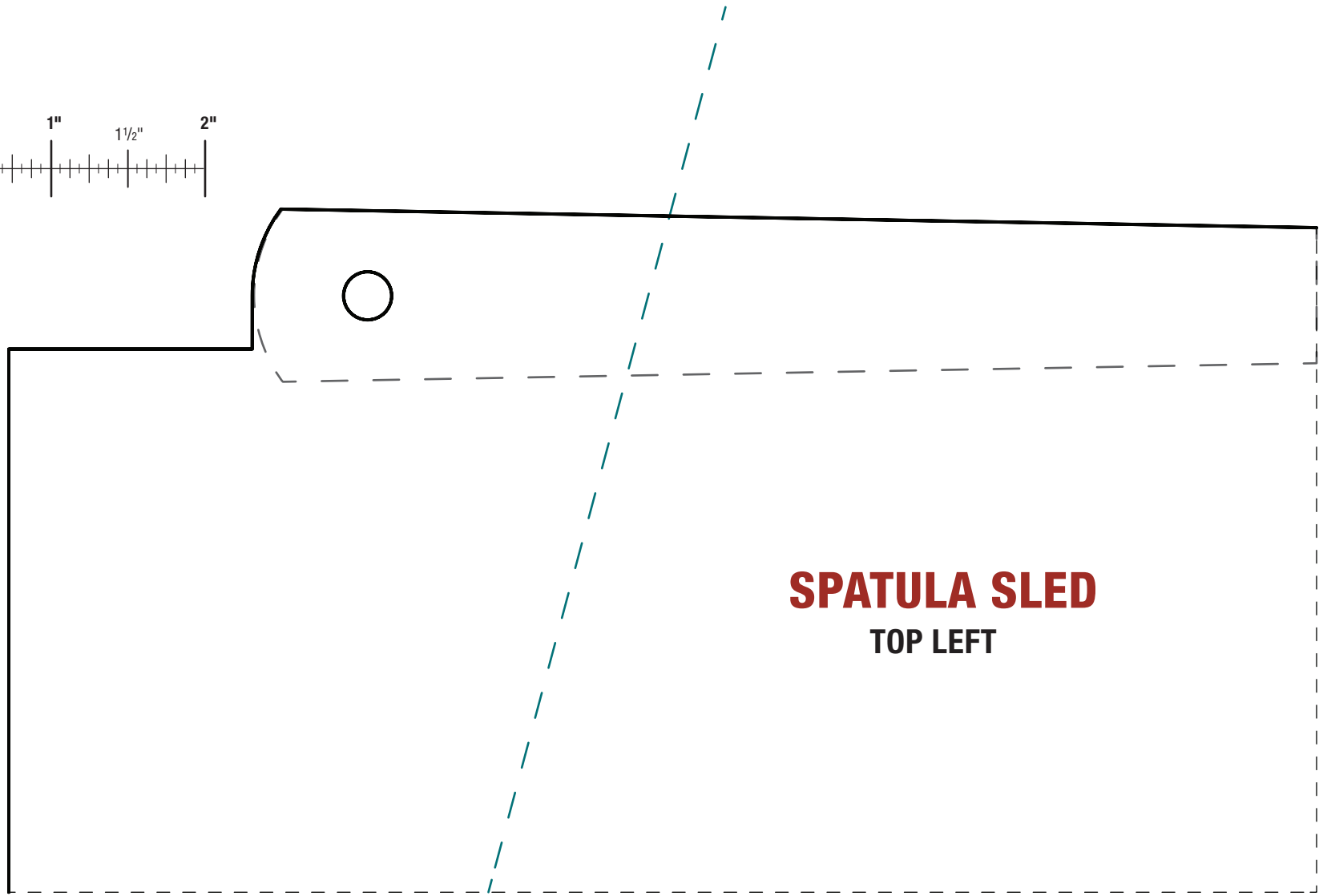

**SPATULA SLED**  
TOP LEFT

**TO ASSEMBLE TEMPLATE:** Print, cut, and tape the two pieces together. Note, there is 1" overlap to ensure accurate assembly.

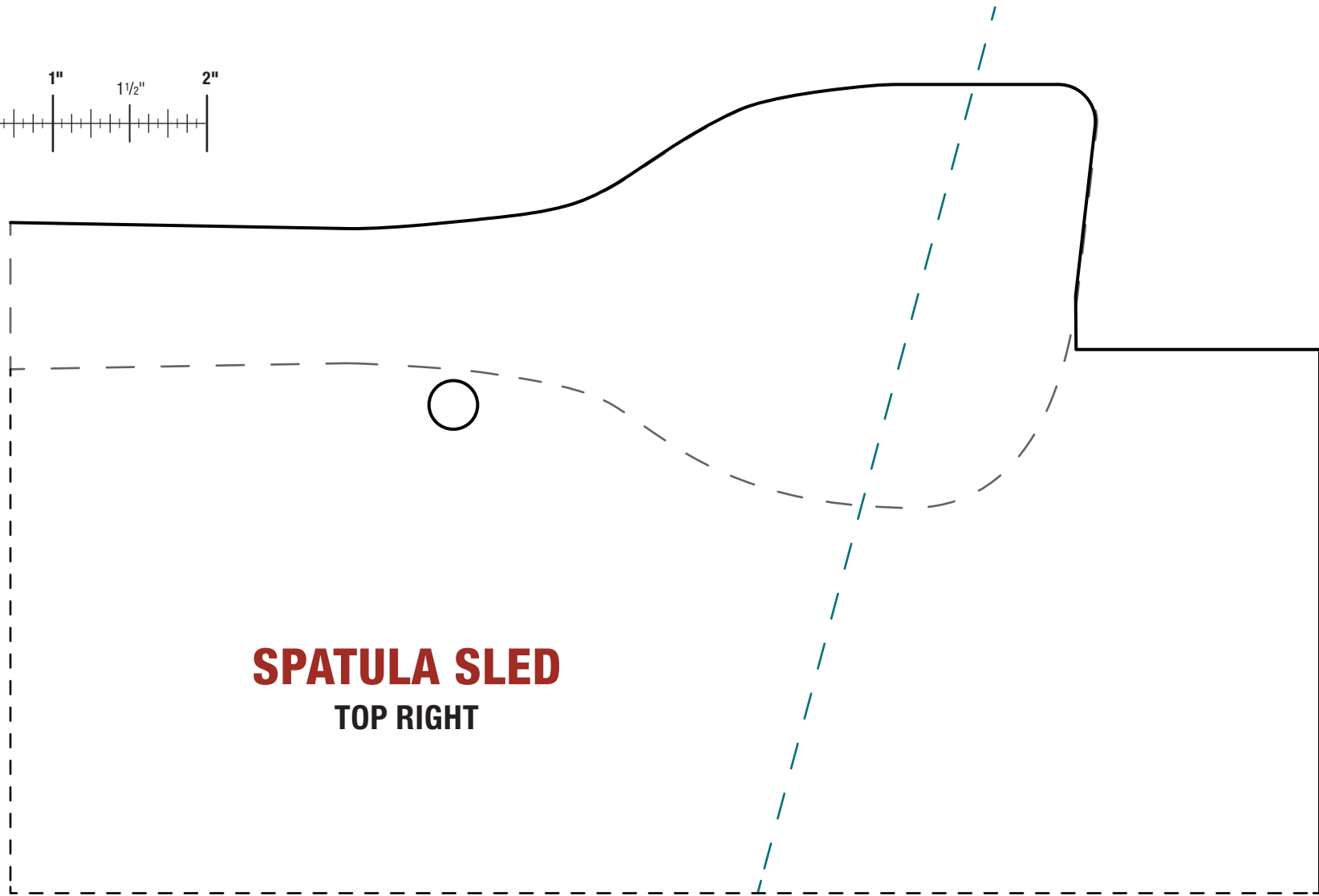
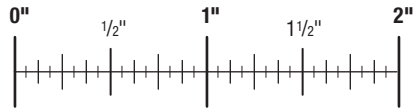

**SPATULA SLED**  
TOP RIGHT

**TO ASSEMBLE TEMPLATE:** Print, cut, and tape the two pieces together. Note, there is 1" overlap to ensure accurate assembly.

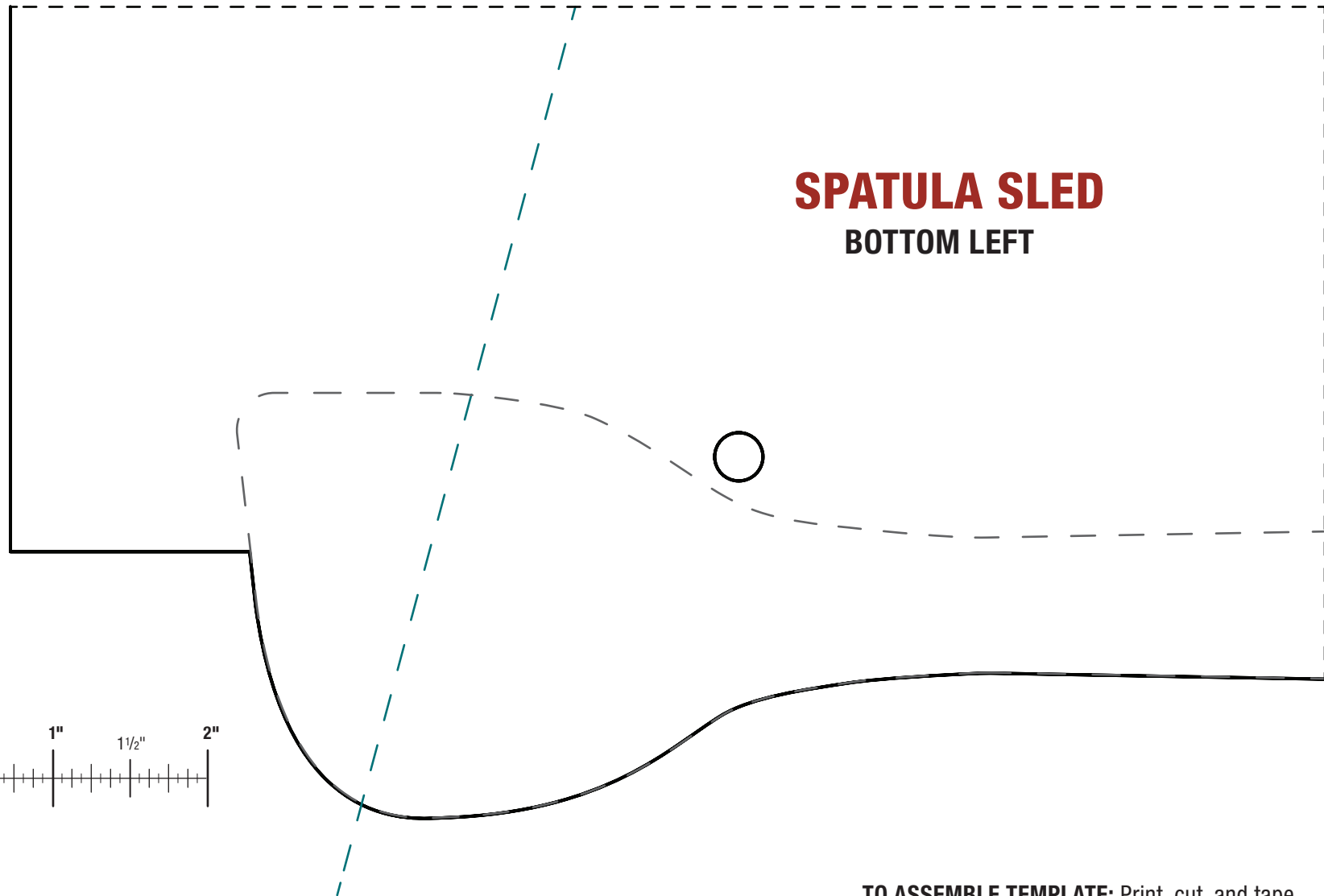

**SPATULA SLED**  
**BOTTOM LEFT**



**TO ASSEMBLE TEMPLATE:** Print, cut, and tape the two pieces together. Note, there is 1" overlap to ensure accurate assembly.

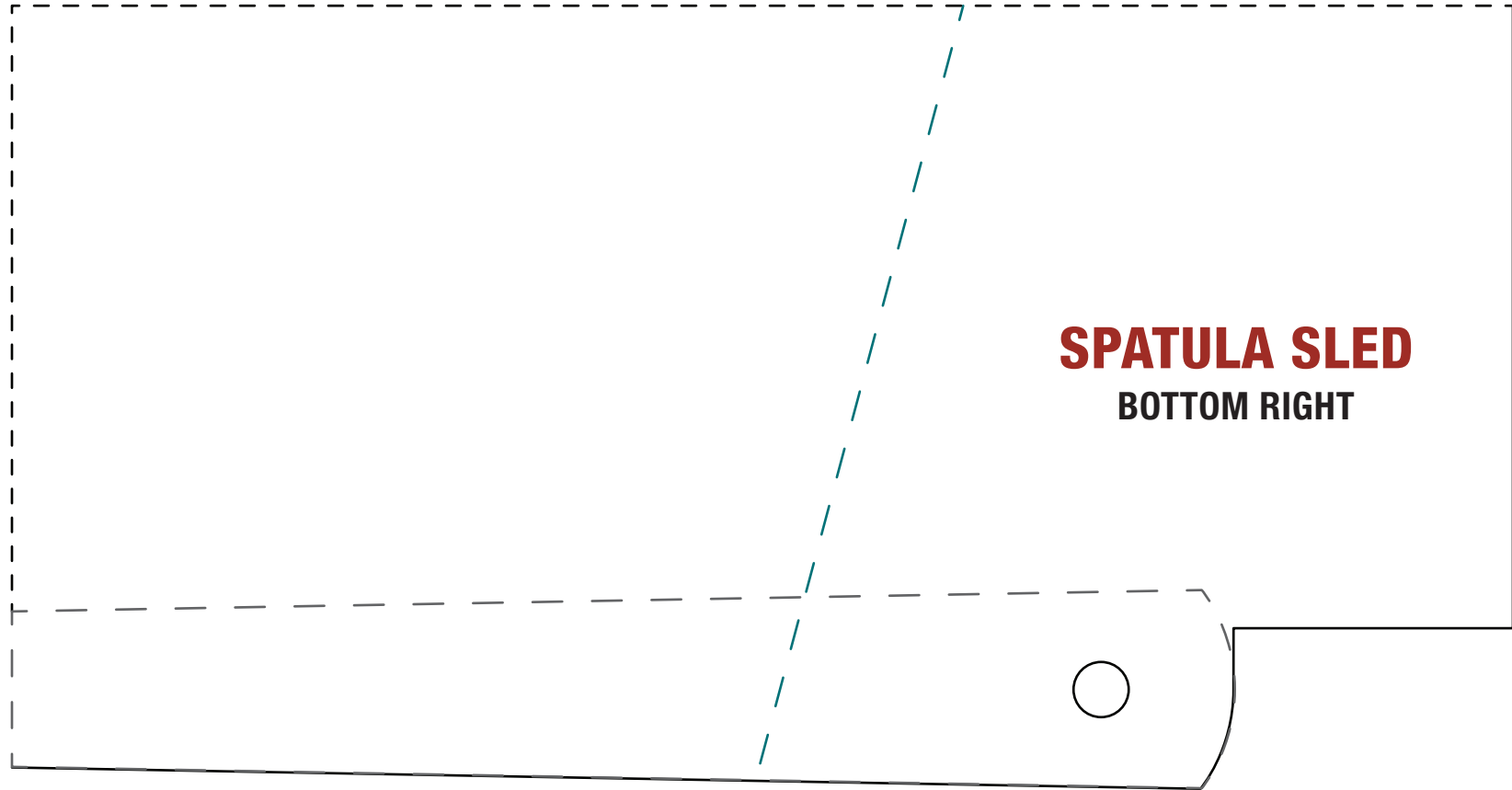

**TO ASSEMBLE TEMPLATE:** Print, cut, and tape the two pieces together. Note, there is 1" overlap to ensure accurate assembly.