

# Building the Perfect Bed

Your bed needs to be one of the toughest pieces of furniture you own. Learn the best way to install traditional bed hardware and then build this stunning pencil-post bed.

**B**uilding a bed is a great project for beginning woodworkers. There aren't a lot of parts, the joinery is simple and the results can be impressive.

We spend one-third of our lives sleeping in bed, but this piece of furniture also is a place to read, watch TV and play with the kids during waking hours. For those reasons, a bed needs to be extra sturdy. You also need to be able to knock it down easily into parts to get it through the door.

The ultimate piece of hardware that satisfies both these needs is the lowly bed bolt. When installed properly, a bed bolt creates the strongest woodworking joint I can imagine. And with a wrench, you can disassemble a bed in minutes.

Sure there are other kinds of bed hardware that attach the rails to the posts, but if you know the tricks to installing bed bolts, you'll never use anything else again.

I've built a lot of beds for clients throughout the years. And one of my most popular designs is this pencil-post bed. In Colonial times, pencil-post beds were draped with curtains at night to conserve heat and increase privacy.

The high posts were never meant to be seen. Over the years the simple straight posts gave way to octagons and more ornate and carved forms.

A lot of plans for pencil posts show the woodworker shaping the octagonal taper with a drawknife. With my method, you can cut a perfect taper in 10 minutes for each post. (*Editor's note: For another method, check out Nick Engler's Ingenious Jigs column on page 28.*)

Even if you don't want to build this particular bed, all of the construction principles apply to whatever type of bed you want to make. Plus, I've included some of the rules to follow when building beds. There aren't many, but they're important.

## Begin With the Posts

This particular bed was made using cherry, but I've made a lot of these in maple, too. Cut your posts from 10/4 rough lumber and cut them about 1" longer than stated in the cut

by Troy Sexton

*Troy Sexton designs and builds custom furniture in Sunbury, Ohio, for his company, Sexton Classic American Furniture. Troy is a contributing editor for Popular Woodworking.*



Try to do as much work on the posts – mortising, drilling, etc. – before you cut the octagonal tapers.

Photo by Al Parrish.





Mark the taper on two sides of each post (below), band saw proud of the line (right) and then joint each face. Mark the taper on the other two faces and repeat.



It takes a steady hand on your router, but it's pretty easy to chamfer the edges of the tapered sides into an octagon (left). Here's a closeup of the end of the post when you've chamfered all four edges (above). It looks a little banged up, but once you cut off that extra 1" it will look perfect.

## STANDARD MATTRESS SIZES

You want your mattress to fit close against the rails. As a rule of thumb, make your rails (between tenons) the same length as your box spring's width and length. With this particular bed design, you'll get the right gap.

	Width	Length
Twin	39	75
Double or full	54	75-80
Queen	60	80-84
King	76	80-84
California King	72	84

## STANDARD BED HEIGHTS

When determining where to put your rails on the posts, aim to end up with your mattress at one of these heights:

- 18" -high Bed: A common height for a platform bed. When you sit on this bed, your knees will be bent.
- 25" -high Bed: The most common bed height. When sitting on the bed, your legs will be mostly extended, but your feet will reach the floor.
- 36" -high Bed: Common on antique beds. When sitting on the bed, your legs will not reach the floor.

list. Joint and plane the posts down to 2 1/4" square.

With the posts square, now is the best time to lay out and cut all the mortises for the rails, the footboard and headboard. All of the mortises are 3/4" wide and 3/4" deep and centered on the posts. My mortiser can handle a 3/4" bit, so I cut the mortises in one pass. If you have a benchtop machine, use a 3/8" bit and cut the mortises in two passes.

If you're building this particular bed, you need to pay extra attention to the mortises for the headboard. Make the bottom mortise so it fits tight around the tenon. But make the top mortise so there's 1/8" slop up and down. This allows the headboard to expand and contract without exploding.



## Make the Pencil Posts

First lay out the taper on the four posts. The taper begins 27" off the floor and then tapers in 5/8" on all four sides.

Because I build so many beds, I made a template that lays out this taper without measuring. You can lay it out using a ruler and a long length of scrap.

Now cut this taper on all four sides using your band saw. Then clean up the saw blade marks by running each face of the post over your jointer.

Next you want to turn that four-sided tapered post into an eight-sided tapered post. The easiest way to do that is with a bearing-guided 45° chamfer bit in a hand-held router. First mark out the octagon shape on the top of the post and set the depth of your router's cut so it's just a little shy of the line. Now mark on all four corners of the post where the taper should end.

Make a test cut on the top of the post (you'll lose the top 1" later, so it can look a little sloppy) and



Clamp your self-centering doweling jig to the tenon and drill the long hole for the bed bolt (above). When it's complete, here's what it looks like (left).

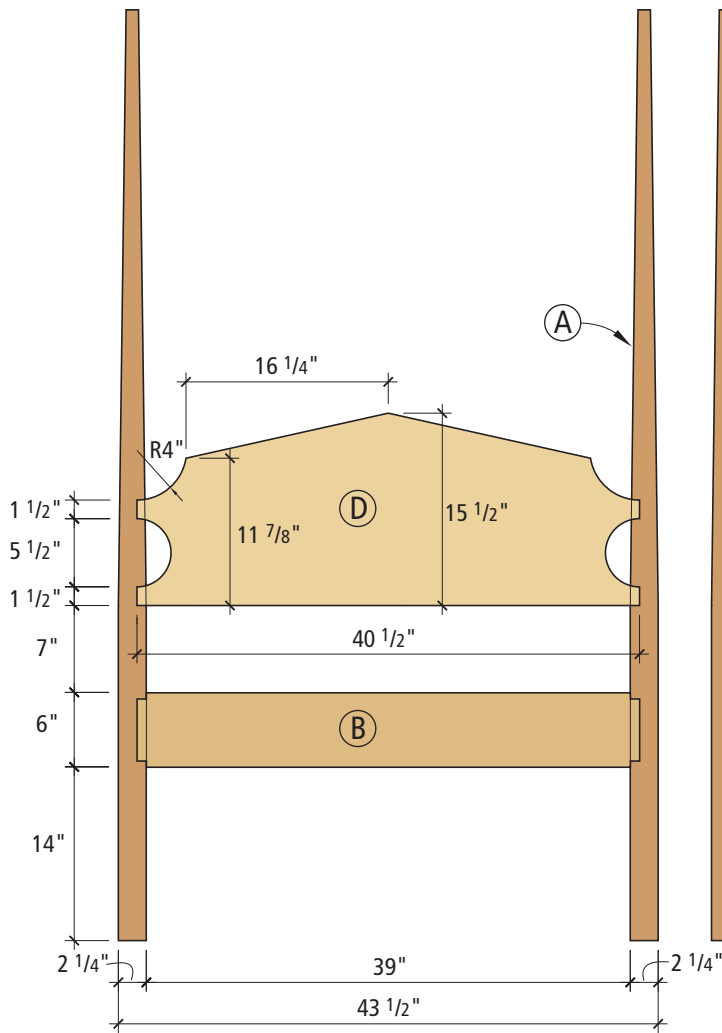

Elevation - headboard

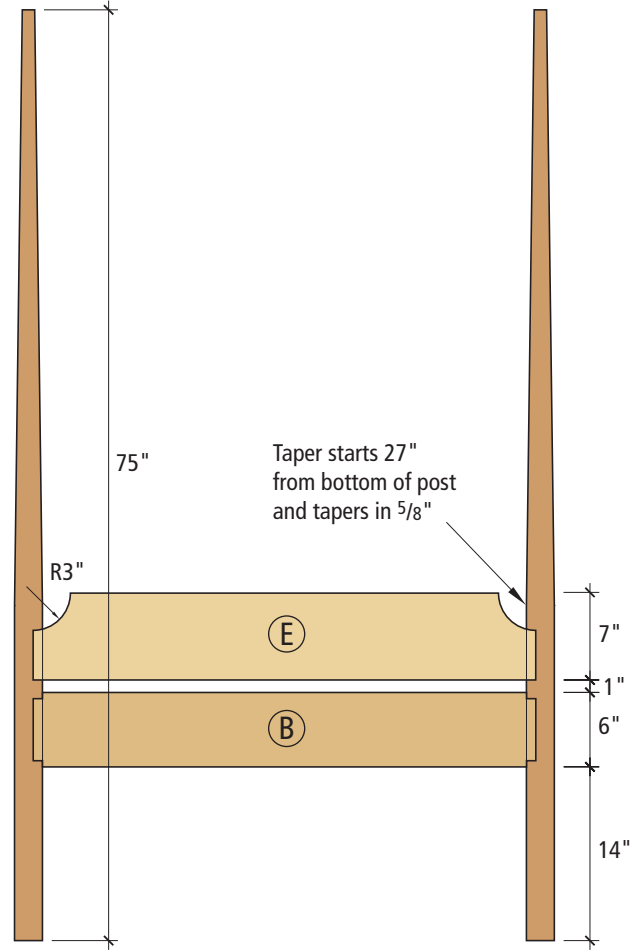

Elevation - footboard

## PENCIL-POST BED

NO.	LET.	ITEM	DIMENSIONS (INCHES)			NOTES
			T	W	L	
4	A	Posts	2 1/4	2 1/4	75	
2	B	Short rails	1 1/4	6	40 1/2	3/4" x 5" x 3/4" TBE
2	C	Long rails	1 1/4	6	76 1/2	3/4" x 5" x 3/4" TBE
1	D	Headboard	3/4	15 1/2	40 1/2	3/4" TBE
1	E	Footboard	3/4	7	40 1/2	3/4" TBE

TBE = tenon on both ends

## RECOMMENDED BED HARDWARE

Whitechapel Ltd., 800-468-5534, [www.whitechapel-ltd.com](http://www.whitechapel-ltd.com)  
 Horton Brasses Inc., 800-754-9127, [www.horton-brasses.com](http://www.horton-brasses.com)  
 Ball and Ball, 800-257-3711, [www.ballandball-us.com](http://www.ballandball-us.com)

- For bed bolts, I use a 6"-long steel bed bolt. In general, bed bolts have a 3/8" square head, a 1 1/16"-diameter flange and 16 threads per inch. You also will want to purchase a bed wrench that makes tightening and loosening the bolts easy. Call the companies above for pricing, shipping information and availability.
- For bed irons, I use 3" x 6" irons. These are made from 1/4"-thick steel that is 1 1/4" wide. Use three irons on each side rail for full, queen or king sizes. Use at least two irons on each side rail for a twin mattress.



Cutting the recess for the nut is easy if you make a jig for your router. The jig simply is a piece of  $\frac{1}{4}$ " ply and some  $\frac{3}{4}$ " scraps that limit the travel of the router.



Again, a simple jig helps me rout the mortises for the bed irons (left). Then it's a simple matter of screwing the irons to the rails (above).

## SUPPORTING THE MATTRESS AND BOX SPRINGS

Essentially, there are five common ways to support your box springs or mattress. If you're building a king-sized bed, you likely need a center support, too.

**Bed Irons:** This traditional and sturdy method is outlined in this article. Note that these work only with a quality box spring. Some inexpensive box springs aren't rigid enough.

**Wooden Cleats:** Screw  $1\frac{1}{2}$ "-square cleats to the inside edge of all four rails and rest the box spring on those.

**Angle Iron:** Screw angle iron (or aluminum angle brackets) to the bottom inside edge of all four rails.

**Cleats and Slats:** If you're building a bed that won't use a box spring, screw square wooden cleats to the inside edge of all four rails and then screw 1 x 4s to the cleats 1" apart.

**Cleats and Plywood:** Screw cleats to the rails and then screw a piece of  $\frac{3}{4}$ "-thick plywood to the cleats.

adjust the depth of your router bit until it cuts right to that line. Now chamfer all four tapered edges. Near the end of the pass, watch the bit and the line you marked on the corner. When the bit hits the line, turn off the router and make the next cut.

Before you finish up with the posts, it's best to cut the  $\frac{7}{16}$ "-diameter clearance holes for the bed bolts in each post. For the bolts that go into the long rails, drill the hole centered on the post and  $\frac{1}{2}$ " above the center of the mortise. For the bolts that go into the short rails, drill the hole centered on the post and  $\frac{1}{2}$ " below the center of the mortise.

By following these instructions, the head of the bed bolt will sit proud of the post. If you want to recess it, you will need to cut a 1" countersink that's  $\frac{5}{8}$ " deep before you drill the clearance holes. Then you'll need to pick out some bed-bolt covers and drill a little deeper into the rails.

Now cut off the top 1" of all the posts and finish sand them. I usually start with 100 grit and proceed up to 180 grit.

### Bed Bolt Basics

Cut all your rails to length. The cut list is for a twin-sized bed, but

you can use the accompanying charts to accommodate other mattress sizes.

Now cut the tenons on the rails. All of the tenons are  $\frac{3}{4}$ " thick, 5" wide and  $\frac{3}{4}$ " long. Clamp the rails and posts together and mark the locations of the clearance holes on the tenons using a pencil. Take the bed apart and get ready to drill the clearance hole for the bed bolt.

I use a self-centering doweling jig with a  $\frac{7}{16}$ " bushing to drill the holes for my  $\frac{3}{8}$ "-diameter bed bolts. If you don't have a  $\frac{7}{16}$ " bush-

ing, a  $\frac{3}{8}$ " will work, too. Bore the hole 4" deep into all the rails.

Now you want to cut a slot that will hold the nut for the bed bolts. The easiest way to do this is with a router. I set up a template guide in my router and made a template that would rout a  $\frac{1}{2}$ "-wide slot that's 1" long. Chuck a  $\frac{1}{2}$ " upspiral bit in your router and clamp the template in place. I routed this slot  $2\frac{1}{4}$ " from the shoulder of the tenon. Cut the 1"-deep slot in several passes.

## DEDICATED BED-BOLT JIG

I build a lot of beds, and I always use bed bolts. For years I used a doweling jig to drill the holes for the bolts in the rails – the technique I show in this article. It works well, but there is (as always) a faster way.

One day I was eyeing my drill press and it came to me. I bought an inexpensive radial drill press and built a simple plywood cabinet to hold the machine on its back. Now I have a simple horizontal boring machine. A fence and a holddown clamp keep the rails in place as I bore the holes. This setup has saved me loads of time. It's not the kind of rig you would want for a home shop, but it's proof that you can jig up just about any operation if you give it enough thought.



Now assemble the joint and snug the bed bolt. When everything looks good, fill the recess with hot-melt glue. Let the glue dry for an hour and then remove the bolt. The glue will hold the nut in place when assembling and disassembling the bed.

### Bed Irons

In my opinion, bed irons are the best way to hold the box spring in place. The irons are simply "Ls" manufactured from 1/4"-thick steel. You can purchase them in a variety of lengths (pre-bent), from 3" long to 10" long.

The length of iron you use is determined by the thickness of your box spring. When the bed is assembled, you want the top of the box spring flush with the top of the rails. For this bed, 6" irons were in order.

You'll probably notice in the photos that when the bed irons are installed they actually will hang down below the rails by 3". This is not a mistake. The bed skirt covers the irons.

I put three irons on each long rail. One iron goes in the center and the other two are 12" from the ends of the rails.

You need to cut a shallow 1/4"-deep mortise for each bed iron. I again made a template for my router and used a straight bit. The template produces a mortise that is 1 1/4" wide and 3" long. Rout the mortises and install the bed irons.

Remove all the hardware and sand your rails up to 180 grit.

### Headboard and Footboard

Glue up the panels you need for the headboard and footboard, cut them to shape on the band saw and sand them up to 180 grit.

You've probably noticed that the tenons on these two parts don't have any shoulders. This is a traditional look. If you want to make you headboard out of thick-



To hold the nut in place while screwing the bed bolt in place, I use one of those telescoping-antenna gizmos with a magnet on the end. If you aren't recessing your bolts in the legs, you don't have to use a bed-bolt wrench to tighten the bolt; an adjustable wrench will do fine.

er stock and cut shoulders on your tenons, that's OK by me.

Break the sharp edges on all the parts using sandpaper and get ready for finishing. I used a red water-based aniline dye on this project followed by a couple coats of lacquer. Cherry will oxidize over time, so a dye or stain is really optional in my book.

When you assemble the bed, make sure not to overtighten the bed bolts. I tighten them until the posts stop wiggling. After every season or two, it's a good idea to check the bolts to make sure they're still snug. This will ensure your bed frame will stay rigid for years to come. **PW**

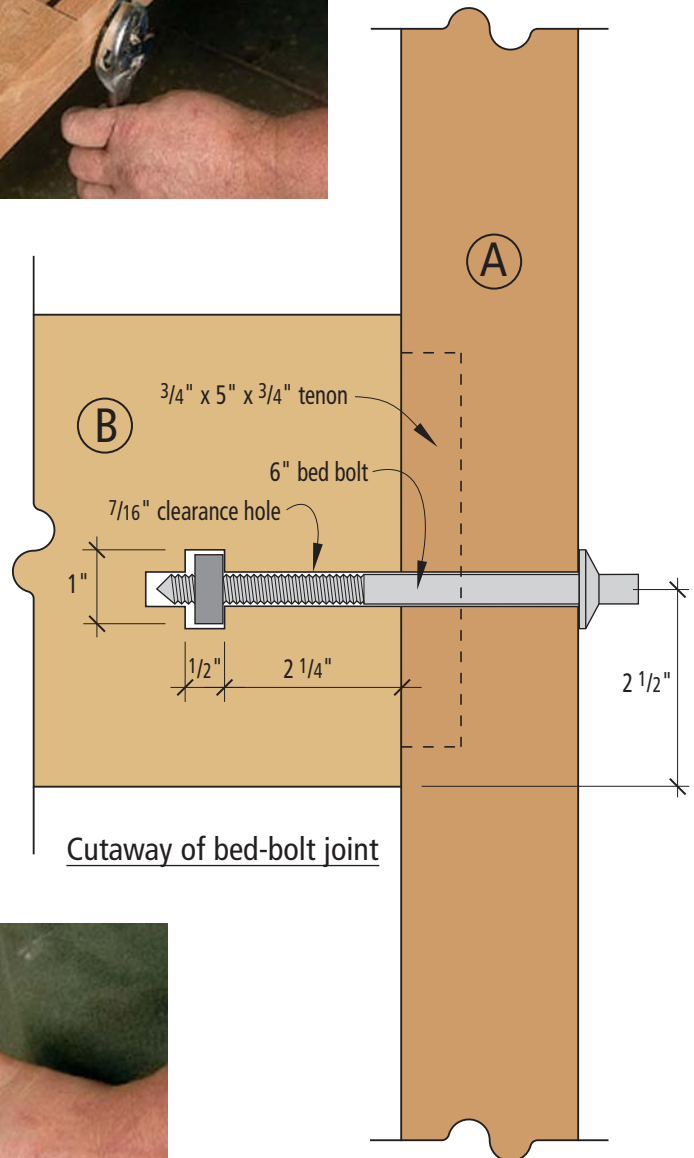

Cutaway of bed-bolt joint



With the nut and the bed bolt in place, fill in the recess with hot-melt glue to keep the nut in position for years to come.